



## DESIGNED FOR MEDIUM VOLUME APPLICATIONS

Five – 4 oz. Servings per Minute – 20 Qt. Capacity

### GREAT FOR RESTAURANTS AND CONCESSIONAIRES

The **SaniServ** model 401 Soft Serv Freezer provides high profit, consistent quality Soft Serv and yogurt products anytime anywhere! Fewer parts to clean and sanitize means rapid disassembly and assembly and the ease of operation makes the 401 a favorite among owners and operators. The increased production, capacity and recovery time make the 401 a perfect piece of equipment for satisfying customer demand and providing the frozen treats they want!

### SPACE SAVING

**Small Footprint Design** - **SaniServ** model 401 saves valuable floor space and turns the countertop into a real profit center by serving high profit ice cream and yogurt products.

### EASY CLEANING AND OPERATION

**Fewer Parts = Simplified Cleaning** – **SaniServ** equipment is designed and built with the fewer parts to be disassembled, cleaned and sanitized than any other machine in the industry. The state of the art solid-state **AccuFreeze** control insures product consistency, worry-free operation and customer satisfaction.

### HIGH RETURN ON INVESTMENT

**Increased Profits** – **SaniServ** machines combine efficiency with consistent product quality and fast quiet operation while insuring customer satisfaction with high profit ice cream or yogurt products.

### QUALITY DESIGN

**Durability** – **SaniServ** machines are built to achieve long and dependable life through simplicity of design. Every machine is shipped standard with a stainless steel exterior, durable steel interior frame construction, heavy-duty components and consistency systems.

# Model 401

Countertop  
Soft Serv  
Ice Cream / Yogurt Machine  
With **AccuFreeze** Control



Made in USA

We reserve the right to change specifications and products design without notice. Such revisions do not entitle the buyer to corresponding changes, improvements, additions or replacements for previously purchased equipment



# MODEL 401

## Counter Model Soft Serv / Yogurt Freezer

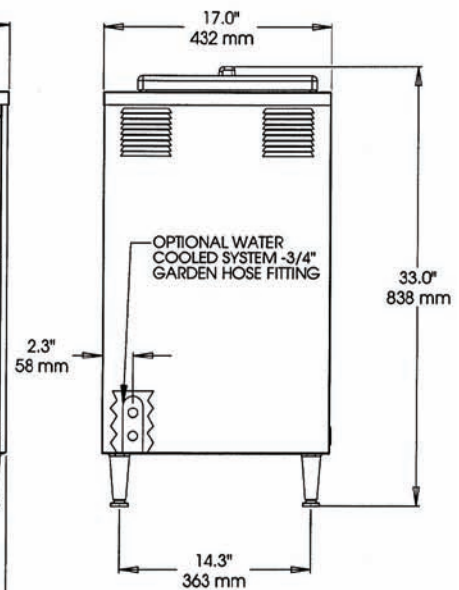
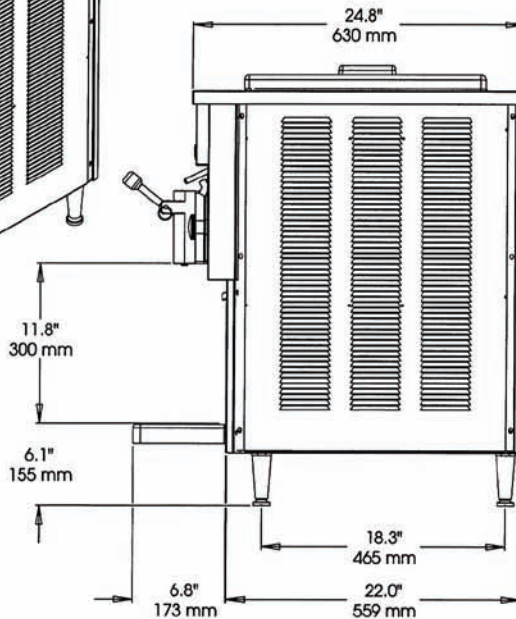
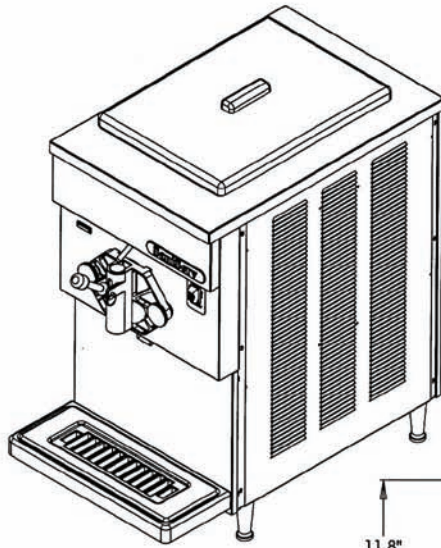

Minimum Wall Clearance  
Both Sides and Back -  
6 inches (152 mm)

ELECTRICAL				WIDTH	HEIGHT	DEPTH	WEIGHT	VOLUME
VOLTS	Hz	Ph.	Amps	INCHES (MM)	INCHES (MM)	INCHES (MM)	LBS. (Kg)	CU FT. (cu. m.)
208-230	60	1	20	17 (432)	33.0 (838)	24.8 (630)	242 (110)	
208-230	60	3	15					
Shipping Specifications				22.5 (572)	41 (1042)	34.5 (876)	272 (124)	18.5 (.53)

### Specifications:

**Cooling System:**

Air or Water

**Dasher and Compressor Motors:**

1 HP Dasher  
1 HP Compressor

**Refrigerant Type:**

R404A

**Listings:**

UL, cUL, NSF

### Features:

**Evaporator and Mix Reservoir**

**Capacity:**

20 Quarts (18.9 liters)

**Dasher:**

Heavy-Duty Stainless Steel with low friction scraper blades.

**Controls:**

**AccuFreeze** solid-state control for accurate product consistency.

**Solid State Audio/Visual Mix Out System with Compressor Lockout**

### Warranty:

Parts 1 year  
Compressor 5 years  
Evaporator 5 years

### Options:

Tune Up Kit  
Parts Tray  
Syrup Rail  
Counter Top Mounting Pad Machine Stand  
Water Cooled - 3/4" Garden Hose Fitting  
Wash Out Kit - 3/8" Flare Fitting