

Indigo™ Series 1000 Ice Cube Machine

Model: ID-1002A IY-1004A ID-1003W IY-1005W ID-1092N IY-1094N



Indigo Series i-1000
Ice Machine on B-570 Bin

Designed for operators who know that ice is critical to their business, the Indigo™ Series ice machine's preventative diagnostics continually monitor itself for reliable ice production. Improvements in cleanability and programmability make your ice machine easy to own and less expensive to operate.

- **Space-Saving Design** – Up to 1,020 lbs. (463 kgs.) daily ice production and only 30" (76.20 cm) wide.
- **Intelligent Diagnostics** – provide 24 hour preventative maintenance and diagnostic feedback for trouble free operation.
- **Acoustical Ice Sensing Probe** – for reliable operation in challenging water conditions.
- **EasyRead Display** – communicates operating status, cleaning reminders, and asset information through a blue illuminated display.
- **Programmable Ice Production** – by On/Off Time, Ice Volume or Bin Level (with accessory bin level control) further improves energy efficiency and savings.
- **Easy to Clean Foodzone** – Hinged front door swings out for easy access. Removable water-trough, distribution tube, curtain, and sensing probes for fast and efficient cleaning. Select components made with AlphaSan® antimicrobial.
- **DuraTech™ Exterior** – provides superior corrosion resistance. Stainless finish with innovative clear-coat resists fingerprints and dirt.
- Available **LuminIce™ Growth Inhibitor** controls the growth of bacteria and yeast within the foodzone.

Ice Machine Electric

208-230/60/1 standard
(208-230/60/3 and 230/50/1 also available.)

Minimum circuit ampacity:

Air-cooled:	13.5 1ph	9.5 3ph
Water-cooled:	9.7 1ph	8.5 3ph
Remote:	10.7 1ph	9.5 3ph

Maximum fuse size:

Air-cooled:	20 1ph	15 3ph
Water-cooled:	15 1ph	15 3ph
Remote:	15 1ph	15 3ph

Specifications

BTU Per Hour:

16,250 (average) 18,600 (peak)

Refrigerant:

R-404A CFC-free

Operating Limits:

- Ambient Temperature Range: 35° to 110°F (1.7° to 43.3°C)
Water Temperature Range: 35° to 90°F (1.7° to 32.2°C)
- Water Pressure Ice Maker Water In:
Min. 20 psi (137.9 kPa)
Max. 80 psi (551.1 kPa)



Ice Shape



Half Dice
3/8" x 1 1/8" x 7/8"
(.95 x 2.86 x 2.22 cm)



Dice
7/8" x 7/8" x 7/8"
(2.22 x 2.22 x 2.22 cm)



2110 South 26th Street
PO Box 1720
Manitowoc, WI 54221-1720 USA

Tel: 1.920.682.0161
Fax: 1.920.683.7589

www.manitowocice.com





Indigo™ Series 1000 Ice Cube Machine

i-1000 on B-570 Storage Bin

- Ⓐ Electrical Entrance (2) Options
- Ⓑ 3/8" (0.95 cm) F.P.T. Water Condenser Inlet (water-cooled units)
- Ⓒ 1/2" (1.27 cm) F.P.T. Water Condenser Outlet (water-cooled units)
- Ⓓ 1/2" (1.27 cm) Auxillary Base Drain Socket
- Ⓔ 3/8" (0.95 cm) F.P.T. Ice Making Water Inlet
- Ⓕ 1/2" (1.27 cm) F.P.T. Ice Making Water Drain
- Ⓖ 3/4" (1.91 cm) Bin Drain

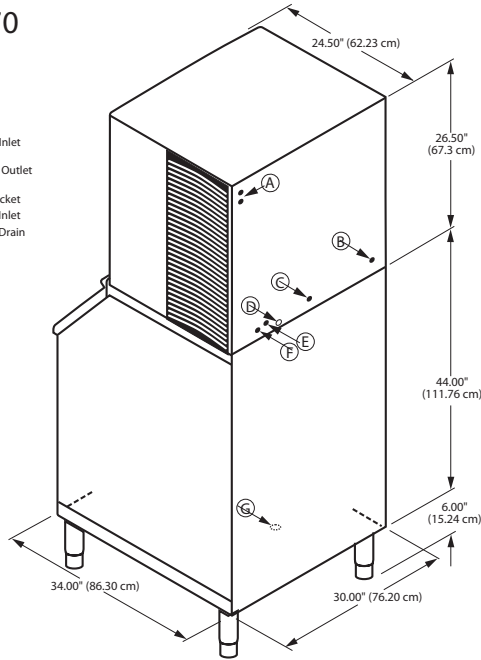

Installation Note
Minimum installation clearance:
Top/sides: 8" (20.32 cm);
Back is 5" (12.7 cm)

Space-Saving Designs



	i-1000 B-570	i-1000 B-970*
Height	76.50" 194.30 cm	76.50" 194.30 cm
Width	30.00" 76.20 cm	48.00" 121.92 cm
Depth	34.00" 86.30 cm	34.00" 86.30 cm
Bin Storage	430 lbs. 195 kgs.	710 lbs. 322.2 kgs.

Height includes adjustable bin legs 6.00" to 8.00", (15.24 to 20.32 cm) set at 6.00" (15.24 cm).

*K-00370 bin adapter required.

Specifications

	Model	Ice Shape	Ice Production 24 Hours		Power Usage kWh/100 lbs. @90°Air/70°F		Water Usage/ 100 lbs. 45.4 kgs. of Ice	ENERGY STAR*
			70°Air/ 50°F Water	90°Air/ 70°F Water	1 Ph	3 Ph	Potable Water	
AIR-COOLED	ID-1002A	dice	990 lbs.	735 lbs.	5.41	5.41	19.8 Gal.	★
			449 kgs.	333 kgs.			75.0 L	
AIR-COOLED	IY-1004A	half-dice	1,010 lbs.	745 lbs.	5.36	5.36	19.8 Gal.	★
			458 kgs.	338 kgs.			75.0 L	
WATER-COOLED	ID-1003W	dice	1,000 lbs.	855 lbs.	4.23	4.23	19.8 Gal.	NA
			454 kgs.	388 kgs.			75.0 L	
WATER-COOLED	IY-1005W	half-dice	1,010 lbs.	870 lbs.	4.07	4.07	19.8 Gal.	NA
			458 kgs.	395 kgs.			75.0 L	
* Water-cooled Condenser Water Usage / 100 lbs. /45.4 kgs. Of Ice: 180 gal/681 L.								
* Water-cooled models are excluded from ENERGY STAR qualification.								
REMOTE-COOLED	ID-1092N	dice	960 lbs.	725 lbs.	5.50	5.50	19.8 Gal.	★
			435 kgs.	329 kgs.			75.0 L	
REMOTE-COOLED	IY-1094N	half-dice	1,020 lbs.	775 lbs.	5.28	5.28	19.8 Gal.	★
			463 kgs.	352 kgs.			75.0 L	

Order ice storage bin separately. Ice storage bin and JC-0995 remote condenser must be ordered separately. Consult remote condenser specification sheet for details. To order 3 phase add "3" suffix to model # (ID-1002A3).

Accessories

LuminIce™ Growth Inhibitor
reduces yeast and bacteria growth for a cleaner ice machine.



Bin Level Control
Allows ice bin level to be automatically set. Built-in LED light illuminates bin.



Arctic Pure® Water Filters
Reduces sediment and chlorine odors for better tasting ice.



AuCS®
schedules and performs routine ice machine cleaning automatically.





LuminIce™ Growth Inhibitor

Model

Factory Built-in Option
(Add "X" to end of Indigo model number)

K-00424 Upgrade Kit
(for Indigo: i-300 to i-1200 and QuietQube i-680C to i-1070C)

K-00434 Upgrade Kit
(for Indigo: i-1400 & i-1800, IB Series, and QuietQube i-1470C to i-2170C)

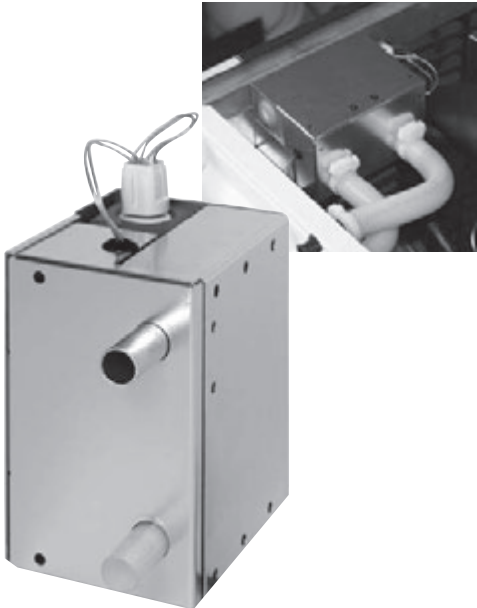

Standard Features

- **Reduced Yeast and Bacteria Growth** – proven by independent lab testing to inhibit the growth of yeast and bacteria for a cleaner foodzone.
- **Easier Cleaning** – reduced slime build up speeds the regularly scheduled cleaning process.
- **Space Saving Design** - device mounts inside the Indigo Series ice machine preserving space clearances in tight areas.
- **Easy to Use** - no chemicals to add or maintain. Only a simple UV bulb change is recommended once a year to maintain effectiveness. *Note: bulb change reminders can be programmed into the Indigo display.*

Warranty

- 3-year warranty covering all parts and labor from the date of original installation (UV bulb is excluded from this warranty).
- UV Bulb replacement part warranty 90 days.

The LuminIce Growth Inhibitor creates "active air" by recirculating the air inside the ice machine food zone over a UV light. This "active air" passes over exposed food zone components to inhibit the growth of yeast, bacteria, and other common microorganisms.

Foodservice operations can often be in challenging environments where it is difficult to prevent yeast, mold and other micro-organism contamination. With LuminIce, testing has shown that ice machine foodzones are noticeably cleaner after only 2-1/2 months of usage.



The LuminIce device runs quietly 24 hours a day keeping your ice machine cleaner and helping to relieve the stress and pain of frequent cleanings. Reduced cleanings ultimately saves labor time, cost, and machine downtime during the cleaning process.

Electric

Electricity drawn directly from ice machine.

Bulb Replacement

To retain maximum effectiveness, annual replacement of the internal UV bulb is recommended. UV bulb shelf life is 3 years from date of manufacture.





How LuminIce Works

UV light acts on the oxygen, nitrogen, and water vapor in the air stream passing across the bulb to create photoplasma.

Photoplasma is a gas that is fully ionized by UV light containing ions, free electrons, hydroxyl radicals, and ozone. Each of which is highly reactive with any microorganisms it encounters within the foodzone. This "active air" is continually recirculated within the foodzone inhibiting microorganism growth.

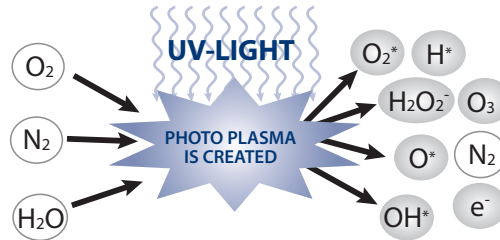

LuminIce (Internal Mounting)

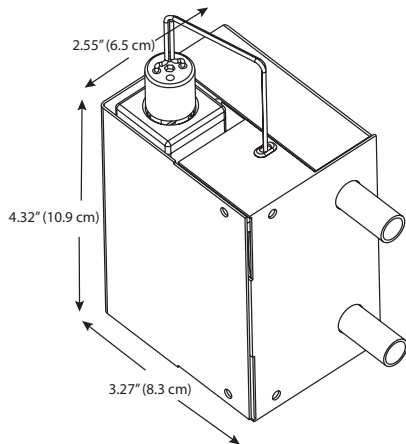

LuminIce UV Bulb

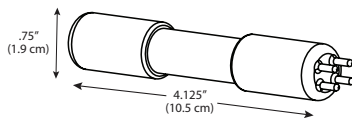

Cleaner Ice Machine Foodzones

Confirmed by Independent Testing Lab

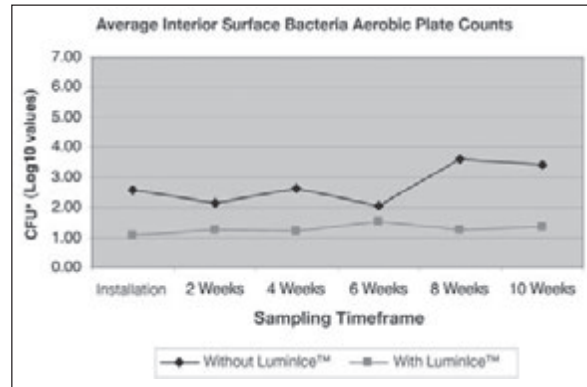
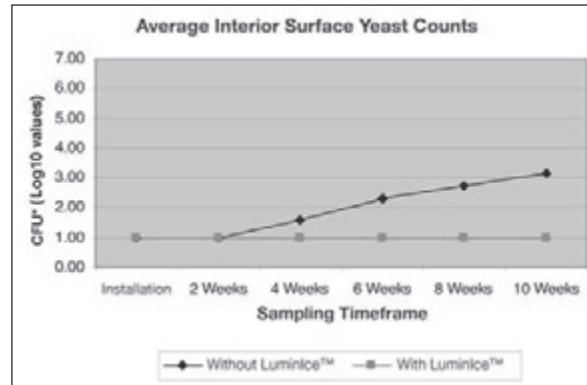

*Average foodzone Colony Forming Units (CFU's) plotted over time from date of installation.

LuminIce Models / Replacement Bulb

Model	Description
X	Factory Built-In LuminIce Growth Inhibitor. Comes pre-installed in ice machine. (Add "X" to end of Indigo model number)
K-00424	LuminIce Growth Inhibitor Kit for Indigo i-300 to i-1200, and QuietQube i-680C to i-1070C.
K-00434	LuminIce Growth Inhibitor Kit for Indigo IB Series, QuietQube i-1470C, i-1870C, i-2170C and 48" i-1400 and i-1800 models.
K-00425	Replacement LuminIce Bulb