



ICEU150

## Features

- Space-saving 24" (610 mm) wide undercounter design.
- Produces up to 174 lbs (79 kg) of ice per day.
- *Harvest Assist* provides consistent ice production for the life of the ice maker while reducing energy consumption and increasing capacity.
- *Pure Ice®* exclusively by Ice-O-Matic. Built-in antimicrobial protection for the life of the ice maker inhibits bacteria growth on ice maker surfaces. Ice-O-Matic's optional water filtration system provides protection against unpleasant tastes, odors and scale formation.
- Durable, electroless nickel plating on all evaporator plates ensures reliability.
- *Longest warranty in the industry.* Purchase an Ice-O-Matic water filter with your cube ice maker, replace the filter every six months, and the evaporator warranty is extended to 7 years parts and labor (available in the U.S. and Canada only).
- Constructed from corrosion-resistant stainless steel and fingerprint-proof plastic.

## Options & Accessories

WATER FILTERS			
Ice Machine Model	Manifold		Inline
	System	Replacement	System
ICEU150	IFQ1	IOMQ (1)	IFI4C / IFI8C

## Ice Maker Warranty

Every Ice-O-Matic ice maker is backed by a warranty that provides both parts and labor coverage.

- Three years **Parts** and **Labor**.
- Five years **Parts** coverage on the evaporator and compressor.
- Seven years **Parts** and **Labor** on the evaporator when you purchase an Ice-O-Matic water filter with your cube ice maker and replace the filter every six months (available in the U.S. and Canada only).

## Ice Form



### CUBE

FULL CUBE DIMENSIONS	
W x D x H (in.)	7 <sup>5</sup> / <sub>8</sub> x 7 <sup>5</sup> / <sub>8</sub> x 7 <sup>5</sup> / <sub>8</sub>
W x D x H (mm)	22 x 22 x 22
HALF CUBE DIMENSIONS	
W x D x H (in.)	3 <sup>5</sup> / <sub>8</sub> x 7 <sup>5</sup> / <sub>8</sub> x 7 <sup>5</sup> / <sub>8</sub>
W x D x H (mm)	10 x 22 x 22

## Space-Saving Solutions

- Front air discharge design for compact spaces.
- Low profile top saves counter space.
- Stores up to 73 lbs (34 kg) of ice.
- Easy front access to ice.
- Available with an air-cooled or water-cooled condenser.



ICEU150 SELF CONTAINED CUBE ICE MAKER

### Air and Water Cooled

- A. Ice maker water in  $\frac{3}{8}$ " FPT.
- B. Bin and ice maker drain,  $\frac{3}{4}$ " FPT.
- C. Hole for electrical connections,  $\frac{7}{8}$ ".
- D. Condenser water in,  $\frac{3}{8}$ " FPT (water cooled units only).
- E. Condenser water out,  $\frac{1}{2}$ " FPT (water cooled units only).

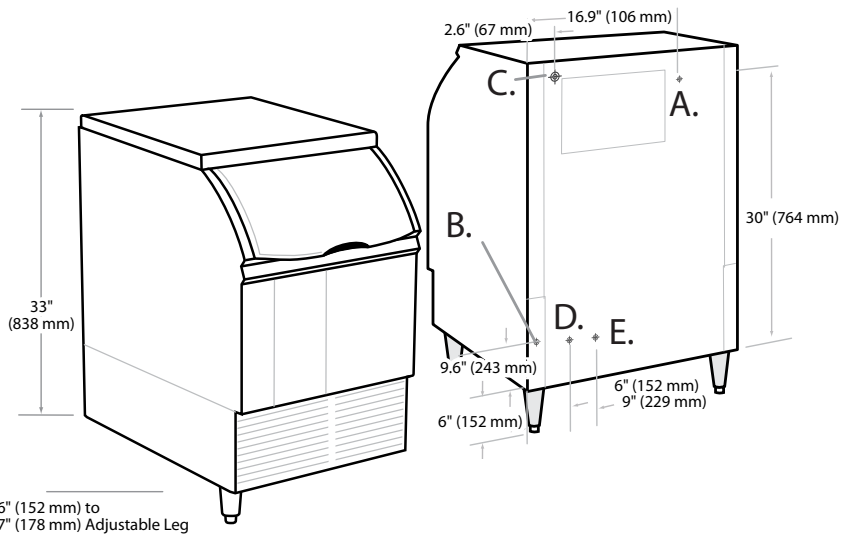
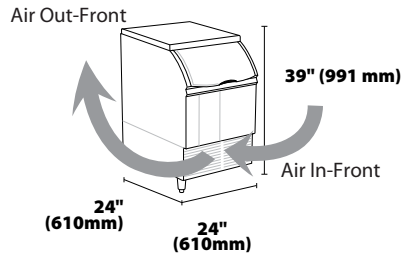

Front & Rear View

### Operating Requirements

	MINIMUM	MAXIMUM
	<b>60 Hz</b>	
Ambient Temp. Range Air	50°F (10°C)	100°F (38°C)
Water Temp.	40°F (4.4°C)	
Water Pressure	20 PSIG (1.4 BAR)	60 PSIG (4.1 BAR)

### Dimensions

ALL MODELS	
W x D x H (in.)	24 x 24 x 39
W x D x H (mm)	610 x 610 x 991

### Specifications

Model Number	Cond. Unit	Ice Production per 24hrs		Water Usage gallons per 100 lbs of Ice 90 F air/70 F water		kWH Used per 100 lbs of ice @ 90 F air/70 F water	Voltage Characteristics	TTL Load Amps	Fuse Size	Approx. BTUs per hour**
		70 F air/50 F water lbs (kg)	90 F air/70 F water lbs (kg)	Potable	Condenser					
ICEU150A★	Air	174 (79)	112 (51)	34.0	-	11.8	115/60/1	9.7	15	3,572
ICEU150W	Water		144 (65)	32.2	152	8.0				7.9

\*\*BTUH is calculated 0°F Evaporator, 100°F Condensing, and 33 PSIG.

#### NOTES:

- Number of Wires: 3 (including ground)
- Approx. Shipping Weight lbs (kg): ICEU150A 160 (73) • ICEU150W 160 (73)
- Refrigerant Type: R404A

★ENERGY STAR qualified machine. Please see our website [www.iceomatic.com](http://www.iceomatic.com) for the latest list of ENERGY STAR qualified machines and available rebates