



Electric Counter Top Pizza Oven w/2 Hearths

Item: CPO-ED-12H

Quantity: _____

Project: _____

Approval: _____

Date: _____

Models:

CPO-ED-12H



Model CPO-ED-12H

Standard Features:

- Incoloy tubular heating elements, (total 3.6 kW)
- 650°F, (343°C), adjustable, electro-mechanical thermostats, one per oven cavity
- One fifteen minute mechanical timer per oven cavity
- 3" crown heights
- Oven ready light indicates oven has reached selected temperature, one per oven cavity
- 1½" thick insulation in walls, top, and doors
- 2 removable baking hearths
- All stainless steel finish
- Standard with 6-ft. (1.8m) long cord and plug
- 208 or 240 volts (please specify at time of order), single phase only
- One-year parts and labor warranty
- 4" adjustable legs

Optional Features:

60-minute timer

Capacity:

- Two (2) 20" pre-baked crust or fresh dough pizzas, (not designed for pan pizza)

Specifications:

Garland Model Number CPO-ED-12H, electric counter top pizza oven. Compact 25-1/2"W x 26-3/4"D size includes a two decks with hearths. Stainless steel exterior. 650°F, (343° C) adjustable electromechanical thermostat and mechanical 15-minute timer. 208 or 240 volt (please specify at time of order), available in single phase only. **Ideal for pre-baked and fresh dough pizza.**



Garland
1333 East 179th Street
Cleveland, Ohio 44110
Phone: 800-424-2411
Fax: 800-624-0218

Garland Commercial Ranges Ltd
1177 Kamato Road,
Mississauga, Ontario
L4W 1X4 CANADA
Phone: 905-624-0260
Fax: 905-624-5669



Electric Counter Top Pizza Oven w/2 Hearths

Electrical Specifications

Voltage	Phase	kW	Nominal Amperes	NEMA Plug	Connection Type
208	1	3.6	17.3	6-20P	6' Line Cord
240	1	3.6	16.3	6-20P	6' Line Cord

Clearances				Shipping	
Installation		Entry		Cu Ft	Wt.
Sides	Rear	Crated	Uncrated		Lb/Kg
1" (25mm)	1" (25mm)	32" (813mm)	27-1/2" (699mm)	10.3	145/66

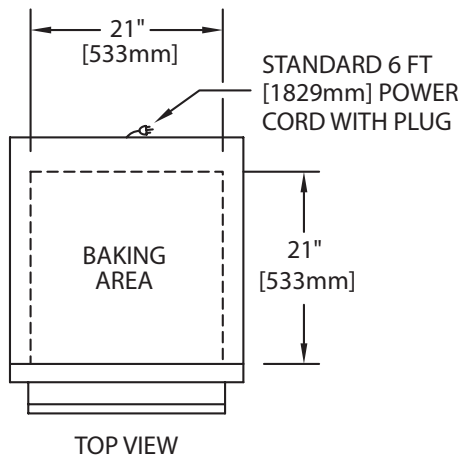

Garland products are not approved or authorized for home or residential use, but are intended for commercial applications only. Garland will not provide service, warranty, maintenance or support of any kind other than in commercial applications.

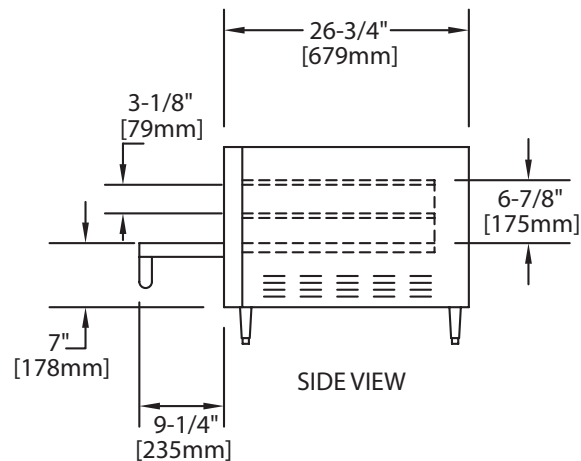
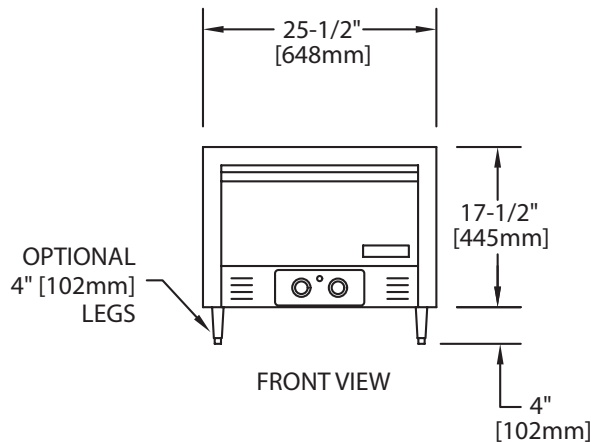

Form# CPOED12 (03/07/11)