



# BEVERAGE-AIR

3779 Champion Blvd., Winston-Salem, NC 27105  
1-888-845-9800 Fax# 1-336-245-6453  
<http://www.Beverage-Air.com>

## Commercial Refrigeration Equipment General Specification

### BREEZE—OPEN-AIR CURTAIN MERCHANDISERS

Used for merchandising and storage of product. Contemporary curved design to fit all modern store layouts.

### CABINET CONSTRUCTION

Heavy duty construction includes white coated steel interior walls. Exterior finish is heavy-duty steel with a baked on durable coating. Choose from black or white finish.

Foamed-in-place CFC and HCFC-free polyurethane insulation enhances the structural strength of the cabinet and helps increase energy efficiency.

Provides easy access with no doors to open. Open front maximizes display of product and helps provide increase sales and profits for the retailer. BZ13 features side shields to maximize product display.

Modern grille is easy to remove for cleaning and servicing.

Brightly lighted sign panel standard on the BZ13.

Gravity-Flo organizers come standard.

### REFRIGERATION

Heavy-duty, high performance one-piece lift-out refrigeration system with hot gas condensate evaporator. No drain required. Refrigeration system on BZ13 utilizes R134a refrigerant.

Product temperatures from 32°F to 40°F.

### ELECTRICAL

Interior lighting provided via two recessed interior lights for maximum product visibility.

Units wired at factory and ready for connection to a 115/60/1 phase, 15 amp dedicated outlet. 8' long cord and plug set included.

	115/60/1 NEMA-5-15P	<b>ELECTRICAL CONNECTION</b> Units pre-wired at factory and include 8' long cord and plug set.
---	------------------------	---

Item No. \_\_\_\_\_  
Quantity \_\_\_\_\_

## OPEN-AIR CURTAIN MERCHANDISER SERIES THE BREEZE

MODELS:  
BZ13



**BZ13**  
shown with optional signage

### SPECIAL FEATURES

- Contemporary curved design with open front
- Gravity-Flo organizers standard
- Brightly lighted sign panel on BZ13

Available From:



\*Note: Not all markings may apply to all model variations.

<b>Model Specified</b> _____	<b>Store#</b> _____
<b>Location</b> _____	<b>Quantity</b> _____



**BEVERAGE-AIR**

**PLAN VIEWS**

**Breeze Open-Air Curtain Merchandiser**  
**Models: BZ13**

MODEL	BZ13
<b>EXTERNAL DIMENSIONAL DATA</b>	
Length Overall (inches)	29 3/4"
Length Overall (mm)	756
Depth Overall (inches)	32"
Depth Overall (mm)	813
Height Overall— (inches)	54"
Height Overall— (mm)	1372
<b>INTERNAL DIMENSIONAL DATA</b>	
NET Capacity (cubic ft.)	13
NET Capacity (Liters)	368
Internal Length Overall (inches)	26"
Internal Length Overall (mm)	660
Internal Depth Overall (inches)	26 3/8"
Internal Depth Overall (mm)	670
Internal Height Overall—(inches)	33 1/2"
Internal Height Overall—(mm)	851
Facings Per Shelf	8
Number of shelves	3
20 Oz. Case Capacity	7
<b>ELECTRICAL DATA</b>	
Full Load Amperes 115/60/1	12
<b>ENERGY CONSUMPTION (KWH)</b>	
	16.7
<b>REFRIGERATION DATA</b>	
Horsepower	1/2
<b>WEIGHT DATA</b>	
Gross Weight (Crated lbs)	350
Gross Weight (Crated kg)	159

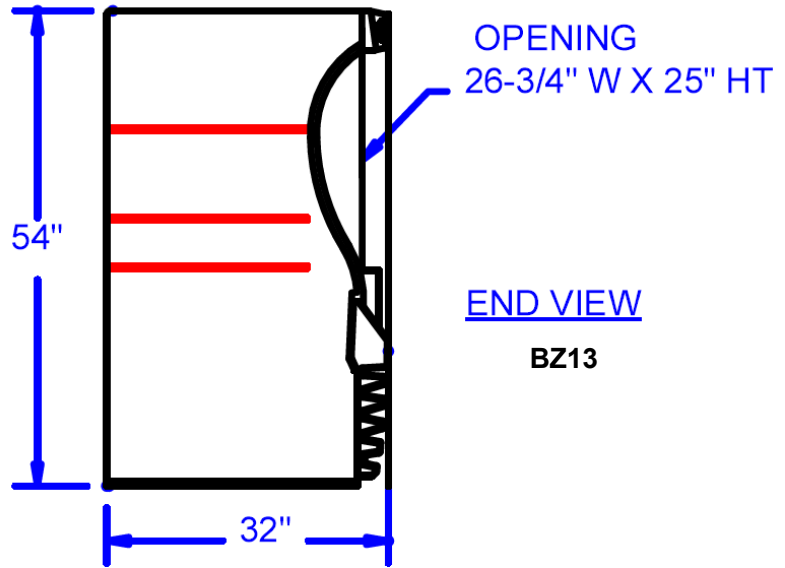

END VIEW  
**BZ13**

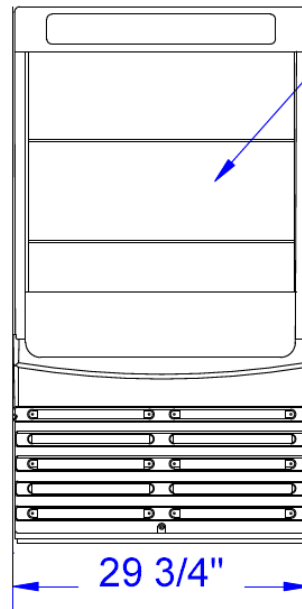

FRONT VIEW  
**BZ13**



\*Note: Not all markings may apply to all model variations.

**BEVERAGE-AIR® CORPORATION**

3779 Champion Blvd. • Winston-Salem, NC 27105 USA • (336) 245-6400 • Fax (336) 245-6453 • (888) 845-9800 • www.beverage-air.com

Specifications are subject to change without prior notice. 06/10