

INSTALLATION AND OPERATING INSTRUCTIONS

COUNTER TOP GAS DECK OVENS

MODELS: GP-51 and GP-61

**INTENDED FOR OTHER THAN HOUSEHOLD USE
RETAIN THIS MANUAL FOR FUTURE REFERENCE
OVEN MUST BE KEPT CLEAR OF COMBUSTIBLES AT ALL TIMES**

IMPORTANT INSTRUCTIONS

After the gas supply has been connected to your unit, it is extremely important to check piping for possible leaks. To do this, use soap and water solution or solutions which are expressly made for this purpose.

DO NOT USE matches, candles, flames, or other sources of ignition since these methods are extremely dangerous. Post in a prominent location instructions to be followed in the event you smell gas. Obtain these instructions from your local gas supplier.

! **For Your Safety:** Do not store or use flammable liquids or vapors in the vicinity of this or any other appliance. **!**

! **Warning:** Improper installation, adjustment, alteration, service or maintenance can cause property damage, injury or death. Read the Installation, Operating and Maintenance instructions thoroughly before installing or servicing this equipment. Initial heating of oven may generate smoke or fumes and must be done in a well-ventilated area. Overexposure to smoke or fumes may cause nausea or dizziness. **!**

Note: Only *Pizza* or *Bread* can have direct contact with ceramic decks. All other food products must be placed in a pan or container to avoid direct contact with ceramic decks.

This equipment has been engineered to provide you with year round dependable service when used according to the instructions in this manual and standard commercial kitchen practices.



P/N U4128A 1/08

BAKERS PRIDE OVEN CO., INC.

30 Pine Street
New Rochelle, NY 10801

(914) 576-0200 Phone
(914) 576-0605 Fax

(800) 431-2745 US & Canada
www.bakerspride.com Web Address

CONTENTS

I. INSTALLATION INSTRUCTIONS		
SECTION	ITEM	PAGE
1.	Receiving.....	2
2.	Clearances.....	3
3.	Set-up.....	3
	(a) Counter Top Installation.....	3
	(b) Installation with Casters.....	3
4.	Deck Assembly.....	4
	(a) Pizza Deck.....	4
	(b) Steel Deck.....	4
5.	Gas and Electric Connections.....	4
6.	Flue connection-Ventilation.....	5
	(a) Under Ventilation Hood.....	5
	(b) Direct Venting.....	5
7.	Main Burner Safety Pilot Operation.....	5
	(a) Pilot Burner Lighting Procedure.....	5
	(b) Pilot Burner Flame Adjustments.....	5
8.	Burner Operation.....	6
	(a) Main Burner.....	6
	(b) Aeration & By-Pass Flame Adjustment.....	6
9.	Thermostat Calibration.....	6
10.	Heat Baffle Assembly.....	6

II. OPERATING INSTRUCTIONS		
1.	Lighting Procedure.....	7
2.	Breaking In.....	7
3.	Baking.....	7
4.	Recommended Operating Procedure.....	7
5.	Helpful Hints.....	7

III. CLEANING AND MAINTENANCE

1.	(a) Oven Exterior.....	8
	(b) Painted Surfaces.....	8
2.	Control Panel.....	8
3.	Flue Vent.....	8
4.	Oven Interior.....	8
	(a) Baking Chamber.....	8
	(b) Baking Decks.....	8
	(c) Burner Compartment.....	8
5.	Troubleshooting Chart.....	9

PARTS LISTS & WARRANTY

GP-51 Parts List w/Exploded Views.....	10
GP-61 Parts List w/Exploded Views.....	13
Warranty.....	16

For European Community Countries:

EN 437 Gas Cat.	Gases and Supply Pressures	Designated European Market = ÿ														
		A	B	D	F	F	G	D	I	I	L	N	P	E	S	G
		T	E	K	I	R	R	E	E	T	U	L	T	S	E	B
I ₂ H	G20 @ 20mbar	ÿ	ÿ	ÿ					ÿ	ÿ			ÿ	ÿ	ÿ	ÿ
I ₂ L	G25 @ 25mbar												ÿ			
I ₂ E	G20 @ 20mbar							ÿ		ÿ						
I ₂ E+	G20/25 @ 20/25mbar	ÿ			ÿ											

For North America:

Type of Gas	Manifold Pressure
Natural	3.5" Water Column
LP	10.0" Water Column

Models Covered

Model	BTU/hr	kw
GP-51	40,000	11.71
GP-52	Consists of two GP-51 Ovens	
GP-54	32,000	9.37
GP-55	Consists of two GP-54 Ovens	
GP-61	45,000	13.18
GP-62	Consists of two GP-61 Ovens	
GP-61-H	60,000	17.57
GP-62-H	Consists of two GP-61-H Ovens	
GP-64	42,000	12.30
GP-65	Consists of two GP-64 Ovens	

These model numbers may be followed by a suffix (-1), indicating units with one door on the Baking Chamber.

I. INSTALLATION INSTRUCTIONS

1. RECEIVING:

Read the notice on the outside carton regarding damage in transit. Damage discovered after opening the crate(s) /carton(s) is 'CONCEALED DAMAGE' and the carrier must be notified immediately to send an inspector and also to furnish forms for the consignee's claim.

When the oven arrives, it should consist of: A carton containing your new oven (**Two for a stacked unit**).

Installation must conform with local codes and/or to the latest edition of the ANSZ-223.1 National Fuel Gas Code in USA (CAN/CGA-B 149.1 or 2 Installation Code in Canada).

In MASSACHUSETTS: All gas products must be installed by a "Massachusetts" licensed plumber or gas fitter. Ventilation hoods must be installed in accordance with NFPA-96, current edition, with interlocks as described in that standard.

This appliance must be installed by a competent person in accordance with the rules in force. In the U.K. Corgi

registered installers (including the regions of British Gas) undertake to work to safe and satisfactory standards. This appliance must be installed in accordance with the current Gas Safety (Installation and Use) Regulations and the relevant Building Regulations / IEE Regulations. Detailed recommendations are contained in the British Standard Codes Of Practice BS 6172, BS 5440:Part 2 and BS 6891.

Place the oven and parts as close as possible to the area of final installation before un-crating.

IMPORTANT FOR FUTURE REFERENCE		
Please complete this information and retain this manual for the life of the equipment. For Warranty, Service and/or Parts, this information is required.		
_____	_____	_____
Model Number	Serial Number	Date Purchased

2. CLEARANCES:

Minimum Clearance from	Combustible Construction	Non-Combustible Construction
Left Side	2" (51mm)	2" (51mm)
Right Side	1" (25mm)	0
Rear	5" (127mm)	2" (51mm)

3. SET UP: The oven must be installed in a well-ventilated area.

Your oven is packed in a carton and strapped to a skid. Remove the oven and carton from the skid before unpacking. Unpack carefully to avoid damage to the oven. If concealed damage is found, follow the instructions detailed in Section 1.

Keep the area around the oven free and clear of combustible materials. Do not store any materials on top of or under any oven. The provision of an adequate air supply to your oven for ventilation and proper gas combustion is essential. As a minimum, observe the clearances detailed in Section 2. Provide adequate ventilation and make up air in accordance with local codes.

Fit the flue diverter (See fig.1) and the flue transition piece into the rectangular opening located at top near the middle rear of the oven for installing the oven under a ventilation hood. For Direct Venting, Optional Draft Hood (Fig. 2) must be used instead of the flue diverter. **Direct Venting not available for European Community Countries.** Local inspectors and ventilation specialists should be consulted to make sure that the installation of the hood conforms to the local codes and requirements (See fig. 3). In UK ventilation requirements as detailed in BS 5440 should be followed.

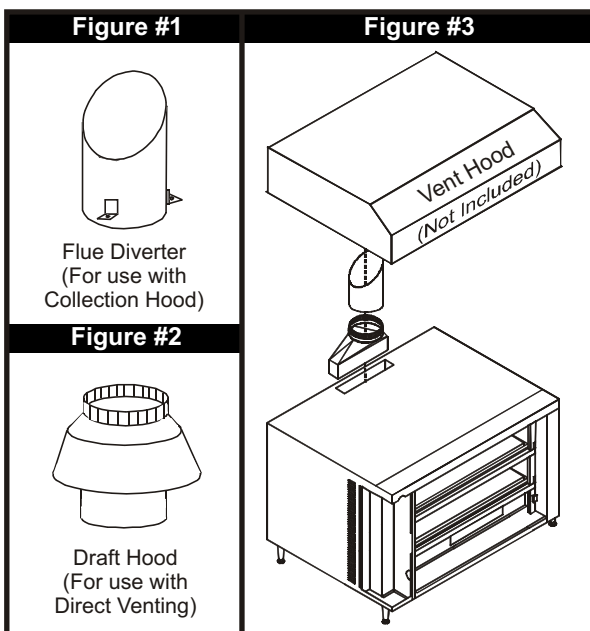

Access to the bottom front door and left side control panel is required for day-to-day operation of the oven and for servicing. Make sure that these areas are kept unobstructed for easy access.

A. COUNTER TOP INSTALLATION:

Oven is shipped with standard 4" legs installed.

- (1) Move the oven to its final location keeping the minimum clearance detailed in section 2 above. This clearance is essential to provide adequate airflow to the burner chamber and for safe operation of the oven.
- (2) Level the oven by making required adjustments to the legs.

B. INSTALLATION WITH CASTERS (OPTIONAL):

Four casters (two with wheel brakes) and the mounting hardware is packed and included in the shipment if ordered. **Install casters with wheel brakes on the front of the unit.**

NOTE: Installation should be made with a connector that complies with the latest edition of the Standard for Connectors for Movable Gas Appliances ANSI Z21.69 in the USA (CAN CGA -6.16 in Canada) and a quick disconnect device that complies with the latest edition of the Standard for Quick Disconnect Devices for use with gas fuel ANSI Z21.41 in the USA (CAN CGA1-6.9 in Canada) and adequate means must be provided to limit the movement of the appliance without depending on the connector and any quick disconnect device or its associated piping.

The restraint should be attached to the rear legs of the oven on which casters are mounted. If disconnection of the restraint is necessary to move the oven for servicing needs, the restraint should be reconnected after the appliance has been returned to its originally installed position.

4. DECK ASSEMBLY:

A. PIZZA DECK:

- (a) Remove all packing material, samples, shims, etc. from the baking chamber.
- (b) Two slabs of the Pizza Deck are provided with the oven. Each deck is wrapped separately. Remove the wrapping and handle the decks carefully. The material is heavy and fragile.

Slab Installation (Fig. 4):

- (a) Slide one deck into the oven over the bottom hearth pan.*
- (b) Slide the second deck onto the support angles on the sides and back.*

B. STEEL DECK INSTALLATION:

Steel decks come installed in the oven from the factory and no assembly is required. Before use, remove all packing material and samples etc. from the baking chamber.

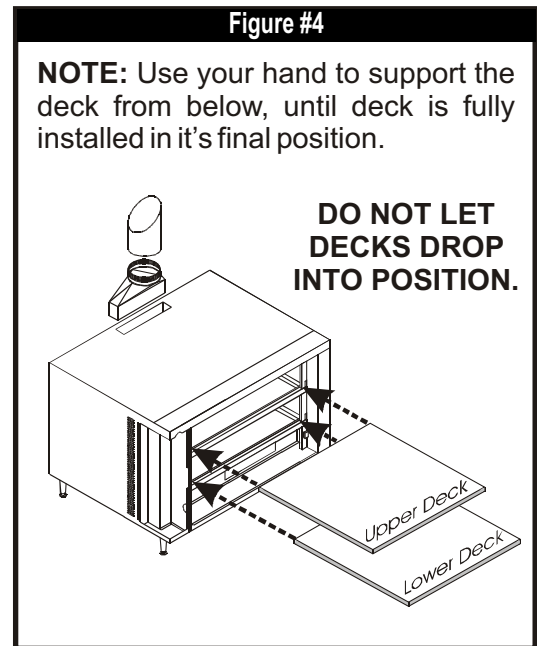

5. GAS AND ELECTRIC CONNECTIONS:

Propane gas units are not available in the European Community Countries.

- (a) The appliance when installed, must be electrically grounded in accordance with local codes and/or the latest edition of the National Electric Code ANSI/NFPA 70 in USA (Canadian Electric Code CSA C22.2 in Canada).
- (b) In Europe, appliance must be connected by an earthing cable to all other units in the complete installation and thence to an independent earth connection in compliance with EN 60335-1 and/or local codes
- (c) The ovens should not be installed on the same line with space heaters, boilers or other gas equipment with high intermittent demand.
- (d) Use a pipe joint compound that is resistant to the action of liquefied petroleum gases when making gas connections.
- (e) For Propane gas, use at least 1/2" (13 mm) pipe or tubing with a 5/8" (16 mm) inside diameter. For Natural gas, use 3/4" (19 mm) pipe.
- (f) The appliance must be isolated from the gas supply piping system by closing its manual shut-off valve during any pressure testing of the gas supply piping system at test pressures equal to or less than 1/2" psig (3.45kpa).
- (g) The appliance and its shut-off valve must be disconnected from the gas supply piping system during any pressure testing of that system at test pressures in excess of 1/2" psig (3.45kpa).
- (h) The gas pressure regulator is part of the combination valve and is adjusted to yield a pressure of 3.5" water column (9mbar) for Natural Gas. If the oven is ordered for use on Propane Gas, the pressure regulator in the combination valve is preset at the factory to yield a pressure of 10" water column (25 mbar). **Units for use on Propane Gas are not available for European Community Countries.**
- (i) A separate shut-off valve for each oven must be provided. It should be as close as possible to the place where the gas supply line goes into the oven. It must be located such that it is

easily accessible.

- (j) When stacking with another oven, two shut-off valves, one for each of the two ovens, must be provided.

After the Gas Supply has been connected, it is extremely important to check all the piping for leaks. Use a soap and water solution or a product expressly made for this purpose. Do not use Matches, Candles or a flame etc to check leaks since these methods are extremely dangerous.

6. FLUE CONNECTION - VENTILATION:

(a) INSTALLATION UNDER VENTILATION HOOD (STANDARD):

If the oven is not vented directly and is installed under a collection hood, use the flue diverter (fig.1) supplied. Local inspectors and ventilation and environmental specialists should be consulted so that the design and the installation of the hood conforms to the local / municipal codes (see fig.3).

(b) DIRECT VENTING (Optional) NOT AVAILABLE FOR EUROPEAN COMMUNITY COUNTRIES:

If direct venting, it is necessary to install a draft hood (fig.2). The flue pipe from the draft hood must not run downwards at any point from the oven to the final outlet. It should always slant slightly upwards. For best results it should rise straight up.

NOTE: Do not put a damper in the flue and do not connect a blower directly to the flue. If the flue runs directly to the free air outside the building, use a wind deflector or a UL listed vent cap at the end of the flue pipe. Termination of the vent must be at least 2 feet above the highest part of the roof within 10 feet (Ref: American Gas Association Catalog No. Xh0474)

7. MAIN BURNER SAFETY PILOT OPERATION:

The purpose of the safety pilot system is to lock the gas supply to the main burner at the combination valve, if for any reason the pilot burner is not lit. Oven should be relighted by following the steps given below. However, in normal service, the pilot flame stays lit indefinitely, day and night or weekends. This prolongs the life of the safety valve.

The safety pilot valve is in effect a two-stage control. After initial lighting, the pilot burner stays on without the gas cock dial being held pressed in. After 1-2 minutes, the valve opens fully to let the gas flow past the safety pilot valve into the burner system.

A. PILOT BURNER LIGHTING PROCEDURE:

- (a) Partially depress and turn the gas cock dial to 'OFF'() position.
- (b) Wait for five minutes to allow gas, which may have accumulated in the burner compartment, to escape.
- (c) Turn gas cock dial to 'PILOT'() position.
- (d) Depress gas cock dial and light Pilot Burner. Hold in pressed position for about ½ minute (30 Seconds), and release the gas cock dial. The Pilot Burner should now remain lit.

If Pilot Burner fails to ignite or does not remain lit, repeat the steps (a) through (d).

B. PILOT BURNER FLAME ADJUSTMENT:

It is important to have the correct Pilot Burner Flame size as shown in Fig.5. If necessary, adjust the Pilot Burner Flame by turning Pilot Adjust Screw (See fig. 6) clockwise to reduce or counter-clockwise to increase.

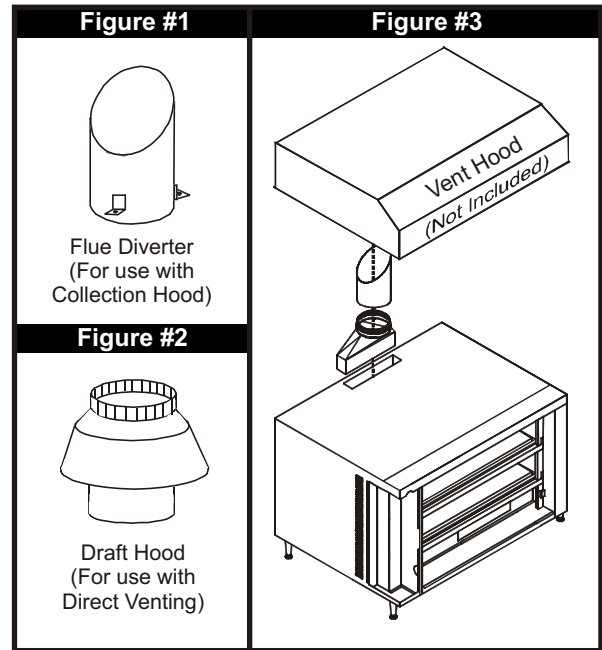

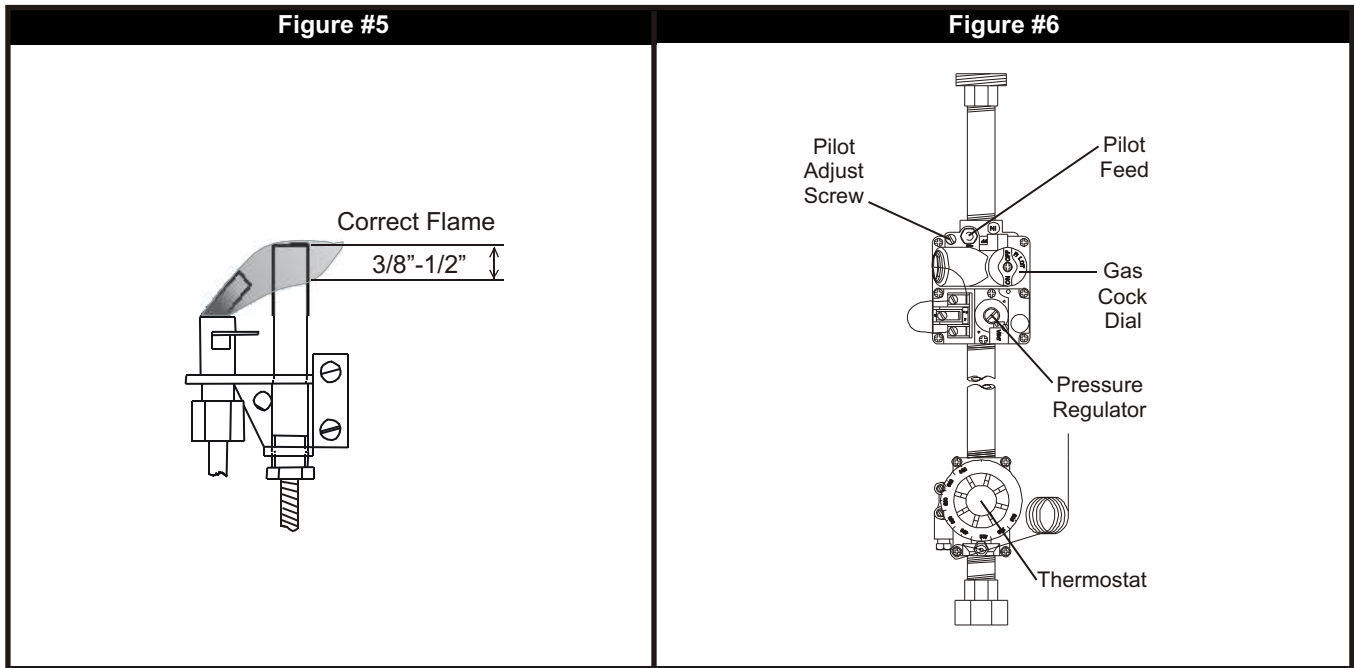

8. BURNER OPERATION:

(a) MAIN BURNER:

After the pilot burner is ignited, when heat is desired, turn gas cock dial to 'ON' () position and set the thermostat dial to the desired temperature. The oven burner flame should always have a blue appearance. That indicates a good mixture of gas and air. When using LP gas, the flame will have a blue-yellow appearance.

Should the Burner fail to light, check to see if there is a problem with the gas supply. If there are other appliances on the same line, shut them off temporarily and see if the burner comes back on, or it fluctuates as other gas appliances are turned on and off. That would indicate overloading of the gas supply lines or a faulty gas pressure regulator. Contact an authorized Service Agency or your local Gas Supply Company.

(b) AERATION AND BY-PASS FLAME ADJUSTMENT:

Flame and air mixer adjustments and the By-Pass Flame adjustment for the Main Burner are done at the factory. These adjustments are sealed before the oven leaves the factory. **Contact an authorized Service Agency if you need help.**

9. THERMOSTAT CALIBRATION:

No attempt should be made to calibrate the thermostat because it is accurately calibrated and sealed by the manufacturer. **Contact an authorized Service Agency if you need help.**

10. HEAT BAFFLE ASSEMBLY:

The Heat Baffle Assembly distributes the heat evenly below the baking deck. It must be in good condition in order to be effective. A damaged Heat Baffle will adversely affect the oven performance. Check it periodically and replace as necessary.

II. OPERATING INSTRUCTIONS

NOTE: Only *Pizza* and *Bread* Products can have direct contact with Ceramic Decks. All other food products must be placed in a pan or containers to avoid direct contact with Ceramic Decks.

If gas odor is detected at any time, immediately shut-off the gas supply valve for the oven. Do not permit any open flames in the area of the oven. Immediately contact an authorized Service Agency or your local Gas Supply Company.

Initial heating of the oven must be done in a well-ventilated area as it may generate smoke or fumes. Over exposure to smoke or fumes may cause nausea or dizziness

1. LIGHTING PROCEDURE:

(a) Light the Main Burner following the instructions in Section 7A of the Installation Instructions.

2. BREAKING IN:

It is important to break-in, to dry out the deck and the insulation, before baking in a new oven:

(a) Allow the oven to warm to 300°F (150°C) for 5 hours or at least till all the smoke and fumes have disappeared. The smoke and fumes are from the moisture in the deck and insulation and a light coat of oil.

(b) Set the thermostat at least 50°F (10°C) lower than your baking temperature.

(c) Pre-heat the oven for 1 to 1½ hours before use.

(d) After pre-heating, raise the temperature to your baking temperature.

(e) Experiment baking until you get the feel of the oven and the speed of the bake.

3. BAKING:

Pizza can be baked on the deck, on a screen or in a pan. When you determine the combination of method, ingredients and temperature that gives the right bake for your crust, sauce and cheese combination and your customer's taste, mark and keep it.

Deck baking refers to baking Pizza directly on the deck. Generally it is a thin product that requires temperature of at least 550°F (290°C).

Screen baking refers to baking Pizza on a screen. The screen lifts the Pizza off the deck. The screen may be removed near the end of the bake time to give the bottom of the Pizza crispier crust and a darker color. Bake temperatures range from 500°F (260°C) to 550°F (290°C).

Pan baking refers to baking Pizza in pans. Crusts can be thick or thin and toppings range from light to heavy. Bake temperatures for pan baking range from 450°F (235°C) to 500°F (260°C).

4. RECOMMENDED OPERATING PROCEDURE:

It is very important that at the end of day's operation, the gas cock dial of the Main Burner is turned to the pilot position, leaving only the pilot burner 'ON' overnight.

Preheating:

(a) Turn the gas cock dial of the main burner to the 'ON' position.

(b) Preheat the oven for 1 to 1½ hours at 50°F (10°C) lower than your baking temperature.

Baking:

(a) When ready to bake, raise the thermostat setting to your baking temperature.

5. HELPFUL HINTS:

(a) If the oven is up to Pizza baking temperature and has not been used for a while, there is a tendency for the baking deck to get hotter. In this condition, when you put in one Pizza, **TURN THE THERMOSTAT UP**, so that the main burner flame is burning at it's fullest, providing the extra heat needed to balance the bottom heat. The thermostat should be turned down back to the normal setting as soon as you have baked the Pizza.

(b) Top section takes longer to bake as compared to the bottom section. Allow 1 to 2 minutes extra bake time for the items placed there.

(c) Frequently scrape and brush off decks to remove burnt residue which can cause an "off" flavor and bake times to increase.

(d) Heavily topped Pizza or Pan Pizza requires lower bake temperatures and longer bake times as compared to a regular thin Pizza with light toppings.

(e) Bubbles in fresh dough indicate under proofed or cold product. Allow the dough balls to proof to double in size and warm temperature before baking.

(f) Any type of Pan or Screen may be used in this oven. When choosing pans, be sure to pick a pan which is closest in height of your product. **Dark color pans and screens transfer heat better than light colored aluminum pans or screens.** They must be seasoned before use.

III. CLEANING AND MAINTENANCE

This appliance must be serviced by an Authorized Service Technician only. Disconnect the power supply before cleaning or servicing the oven.

Regular and thorough cleaning will help to keep the ovens operating properly. If service is required, contact an Authorized Service Agency, your dealer or the factory to obtain a qualified technician for the required maintenance/service.

1A. OVEN EXTERIOR:

- (a) Deposits of baked-on splatter and grease, or discoloration may be removed with the stainless steel cleaner sample supplied or by using any commercial cleaner recommended for stainless steel. Bakers Pride offers a stainless steel cleaner expressly for this purpose. RINSE WELL
- (b) A thin coat of light oil will add to the appearance of the oven.

NOTE: Apply stainless steel cleanser only when the oven is cold. Always rub with the grains and apply very light pressure.

1B. PAINTED SURFACES:

- (a) Washing with mild soap and water solution is adequate to keep the painted surfaces clean.
- (b) Apply a thin coat of oil to protect and enhance the finish

2. CONTROL PANEL:

Every six months (more frequently if the oven is used heavily) the bottom door spring mechanism and all moving parts must be inspected for wear.

Do not apply grease to spring lever shoulder bolt, spring roller or the door rod and the door pin. They have a self-lubricating insert that will be damaged if lubricated.

3. FLUE VENT:

Ventilation system must be inspected every six months and maintained clean and free of obstructions.

4. OVEN INTERIOR:

Clean the oven interior only when the oven is cold. Use only the detergent solutions and cleaners that meet the national and / or local codes.

(a) BAKING CHAMBER:

Clean the ceiling and the walls of the baking chamber with a mild soap and water solution. **Do not use oven cleaners, caustic solutions or mechanical means as they will damage the interior aluminized surface.**

(b) BAKING DECKS:

The baking decks are heavy and fragile. They should be handled carefully.

The baking decks should be cleaned by using a long-handled scraper and stiff wire brush. At the end of each day, turn the thermostat up to its maximum setting and let the oven sit at that temperature for at least ½ hour. This will burn off the food spilled onto the baking decks during day's production and turn it into ash. This ash can be brushed off the next day before turning the oven on. The baking decks should be scraped and brushed during the day also to help keep them clean. To remove excessive crumbs or carbon, the baking decks and the oven cavity may be vacuumed when the oven is cold. **Do not use water or other liquids on the baking decks as that may cause them to crack.** After long use, heavily soiled baking decks may be cleaned by turning over after scraping down and brushing off. This will burn off the heavily soiled side of the baking decks. This procedure may be repeated as needed.

(c) BURNER COMPARTMENT:

Vacuum out any carbon, crumbs or residue in the burner compartment and all around the doors. The holes and louvers on the outer surfaces of the oven must be kept free of obstructions to allow free movement of air into the controls and for proper combustion. The burner ports and crossover holes should be kept free of carbon and other deposits.

5. TROUBLESHOOTING CHART

PROBLEM	PROBABLE CAUSE	REMEDY
No Pilot Light	Gas valve feeding oven may be in the closed position.	Turn gas valve on. Relight pilot.
Main Burner(s) do not light	Gas valve feeding oven may be in the closed position	Turn gas valve on. Relight pilot.
	Thermopile may not be positioned in pilot flame.	Ensure that the tip of thermopile is in pilot flame.
	Thermopile may be defective.	Call local authorized Bakers Pride Service Agent.
Oven too Hot	Thermostat set too high.	Lower the thermostat setting and see if flame reduces in size. Allow several hours for heat to regulate.
	Thermostat or thermocouple may be defective.	Call local authorized Bakers Pride Service Agent.
Bottom of pies are undercooked	If the same area of the deck is used repeatedly, the deck temperature in that area will be reduced.	Rotate pies to unused areas of the bake deck that are hotter and will cook the bottoms faster.
Bottom of pies burn before toppings are cooked	Deck temperature too hot - especially during slow periods.	Reduce Thermostat setting by 50° - 75° below normal bake temperature. When decks cool begin cooking and immediately increase the thermostat setting by 50° - 75°.
	Oven was left "ON" overnight.	Oven must be turned to "Pilot" position overnight. It should not be left on a high temperature setting.
	Exhaust fan too powerful.	Reduce fan speed.
Pies cook unevenly	Area's adjacent to oven walls are generally hotter.	Rotate pies (180°), once during each bake or keep to the center of oven.
Oven does not turn On or Off on time. (Ovens equipped w/auto oven starter only)	Power cord not plugged in.	Plug unit in.
	Electrical outlet fuse/circuit breaker is tripped.	Replace fuse or reset circuit breaker.
	Timer incorrectly set.	Reset Timer.
Unit takes too long to reach temperature	Gas volume or gas pressure may be inadequate.	Contact gas supplier. Call local authorized Bakers Pride Service Agent.
	Thermostat or thermocouple may be defective.	Call local authorized Bakers Pride Service Agent.

GP-51

Counter Top Gas Oven

30 Pine Street • New Rochelle • New York • 10801

914 / 576 - 0200

914 / 576 - 0605 fax

1 - 800 - 431 - 2745 US & Canada

www.bakerspride.com web address



Figure A Exterior / Decks / Burner Compartment / Door Rod / Interior Trim

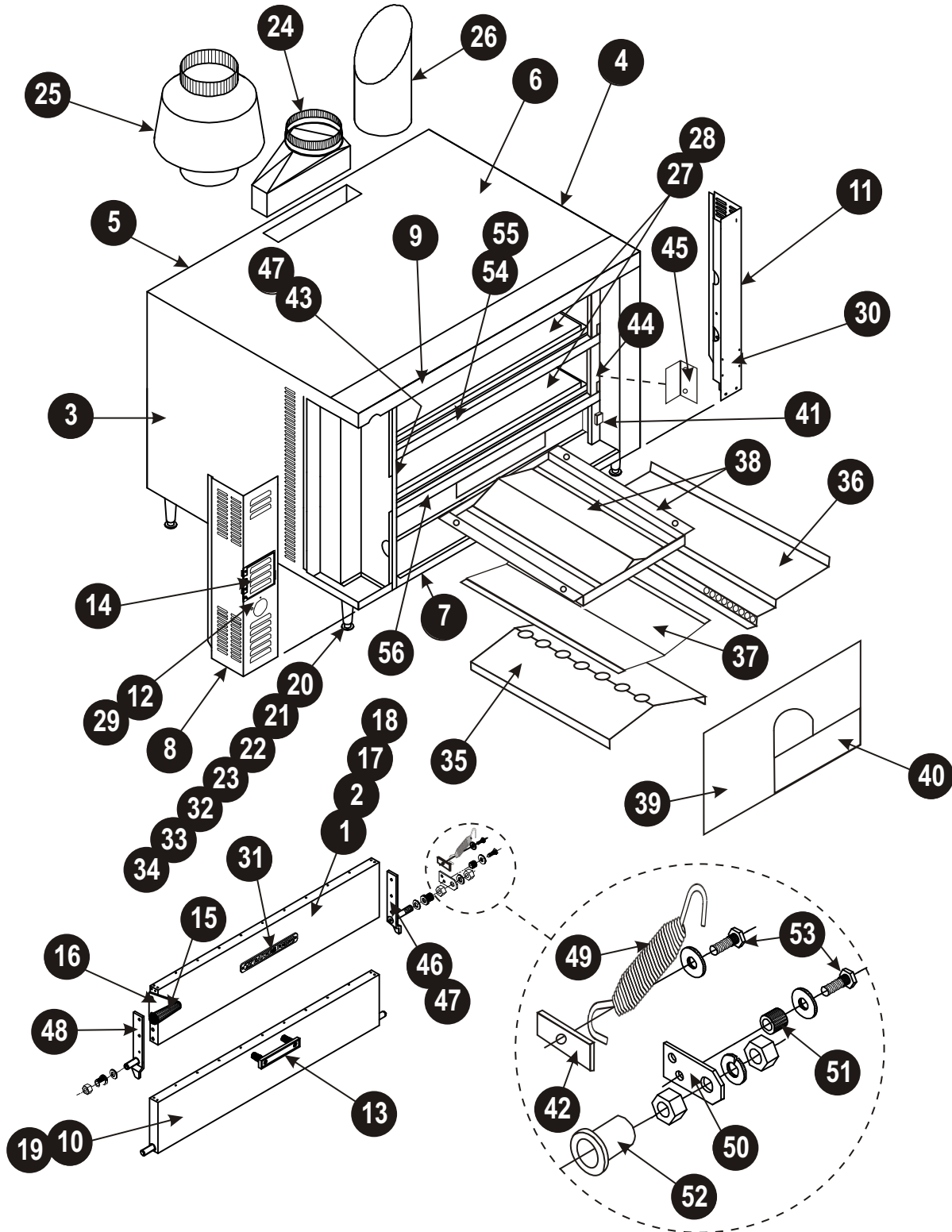

Note: When ordering, ALWAYS specify Part #, Model #, Serial # and type of gas.

9/05



30 Pine Street • New Rochelle • New York • 10801
 914 / 576 - 0200
 914 / 576 - 0605 fax
 1 - 800 - 431 - 2745 US & Canada
 www.bakerspride.com web address

GP-51

Counter Top Gas Oven

Item	Part #	Description	Item	Part #	Description
Exterior / Decks					
1	A5329U	S/S Top Door Cover 14"	18	A5329U	Top Door 14"
2	A5330K	S/S Top Door Cover 7"	19	A5338X	Burner Door
3	A5231X	Left Outer S/S Side	20	S1014A	4" Leg Adjustable
4	A5232X	Right Outer S/S Side	21	S1050Y	30" Leg Painted Gray
5	A5333X	Back Outer S/S	22	S1212Y	30" Leg S/S
6	A5334X	Top Outer S/S	23	S1241Y	16" Leg S/S
7	A5335X	Bottom Trim	24	R3087X	Flue Adapter 6"
8	A5226X	Control Panel	25	R3002Y	Direct Vent Draft Flue 6"
9	A5336K	Top Trim	26	R3103X	Collection Hood Draft Flue w/o Tabs
10	A5338T	Burner Door Cover S/S	27	T1192Y	Ceramic Deck (each)
11	A5227X	Right Front Panel S/S	28	T1192X	Ceramic Deck (set of 2)
12	A4129X	Control Panel w/Lighting Instr. Plate	29	U1172X	Lighting Instruction Plate
13	S1149X	Burner Door Handle w/Screw	30	U1140X	Minimum Clearance Plate
14	A4129X	Control Door	31	U1044X	Bakers Pride Name Plate 8"
15	S1300X	Top Door Handle w/Screw	32	T8089X	Leg Shelf
16	A5253X	Door Handle Mount	33	S1022X	4" Casters w/No Locks
17	A5330T	Top Door 7"	34	S1023X	4" Casters w/Locks
Burner Compartment					
35	A5258X	Upper Breather Pan	39	A5301K	Combustion Chamber Front Center
36	A5321K	Flue Deflector (Set: Left & Right)	40	A5302K	Burner Access Cover
37	A5237X	Slide Out Flame Diverter	41	S3203X	Magnetic Latch Assembly
38	A5341K	Insulation Pan (Set: Top & Bottom)			
Door Rod & Accessories / Interior Trim					
42	A5288X	Spring Bracket	49	S3105X	Door Spring (used with 14" door)
43	A5291X	Left Door Stop	50	A5295X	Lever Arm
44	A5292X	Right Door Stop	51	S3007X	Roller
45	A5293X	Door Stop Shield (Fits on Left or Right)	52	S3008X	Bushing
46	A5297X	Right Door Arm Assembly	53	Q2301X	Shoulder Bolt
47	A5308X	Right Door Arm Assembly (Complete)	54	A5325U	Upper Deck Trim Assembly 7" Door
48	A5296X	Left Door Arm Assembly	55	A5339U	Upper Deck Trim Assembly 14" Door
49	S3004X	Door Spring (used with 7" door)	56	A5324U	Lower Deck Trim Assembly (All)
Quan	Part #	Description	Quan	Part #	Description
BGOR Conversion Kit (From Nat. to L.P)			BGOR Conversion Kit (From L.P. to Nat.)		
1	R3077X	Burner Orifice L/P (Drill #48)	1	R3177X	Burner Orifice N/G (Drill #30)
1	M1245X	Pilot Orifice L.P.	1	M1244X	Pilot Orifice N/G
1	M1221X	L/P BGOR or BMVR Valve Conversion Kit	1	M1297X	N/G BGOR Valve Conversion Kit

9/05 **Note: When ordering, ALWAYS specify Part #, Model #, Serial # and type of gas.**

GP-51

Counter Top Gas Oven

30 Pine Street • New Rochelle • New York • 10801

914 / 576 - 0200

914 / 576 - 0605 fax

1 - 800 - 431 - 2745 US & Canada

www.bakerspride.com web address



Figure B	Burner	Item	Part #	Description
	57	L5094X	Burner w/Inspirator to Union w/o Orifice	
	58	L5096X	Burner w/Cap & Elbow	
	59	M1220X	Pilot Burner N/G	
	60	M1222X	Pilot Burner L/P	
	61	M1244X	Pilot Orifice N/G	
	62	M1245X	Pilot Orifice L.P.	
	63	R3036X	S/S Pilot Tubing 45"	
	64	L5032X	Inspirator #2	
	65	R3075X	Spud Assembly #2 w/o Orifice	
	66	R3177A	Burner Orifice N/G (Drill #30)	
67	R3077X	Burner Orifice L/P (Drill #48)		
68	R3080X	Blank Spud #2 (For #2 Inspirator)		
69	M1296X	Thermocouple T-46 (Used w/BGOR)		

Figure C	Plumbing Control	Item	Part #	Description
	70	M1392X	Control Assy To Union N/G (BGOR)	
	71	M1393X	Control Assy To Union L/P (BGOR)	
	72	M1005X	Thermostat	
	73	S1056X	Thermostat Knob "F"	
	74	S1163X	Thermostat Knob "C"	
	75	R3152X	7000 Combo Valve N/G (BGOR)	
	76	R3154X	7000 Combo Valve L/P (BGOR)	
	77	M1297X	N/G BGOR Valve Conversion Kit	
	78	M1221X	L/P BGOR Valve Conversion Kit	
	79	R3156X	7000 Combo Valve N/G (Europe-BGOR)	
N/S	Q4021X	Capillary Clip (Thermostat Sensor)		
MISCELLANEOUS				
N/S	A5173S	Stacking Bracket Kit		

Note: When ordering, ALWAYS specify Part #, Model #, Serial # and type of gas.

9/05

GP-61

Counter Top Gas Oven

30 Pine Street • New Rochelle • New York • 10801

914 / 576 - 0200

914 / 576 - 0605 fax

1 - 800 - 431 - 2745 US & Canada

www.bakerspride.com web address



Figure A

Exterior / Decks / Burner Compartment / Door Rod / Interior Trim

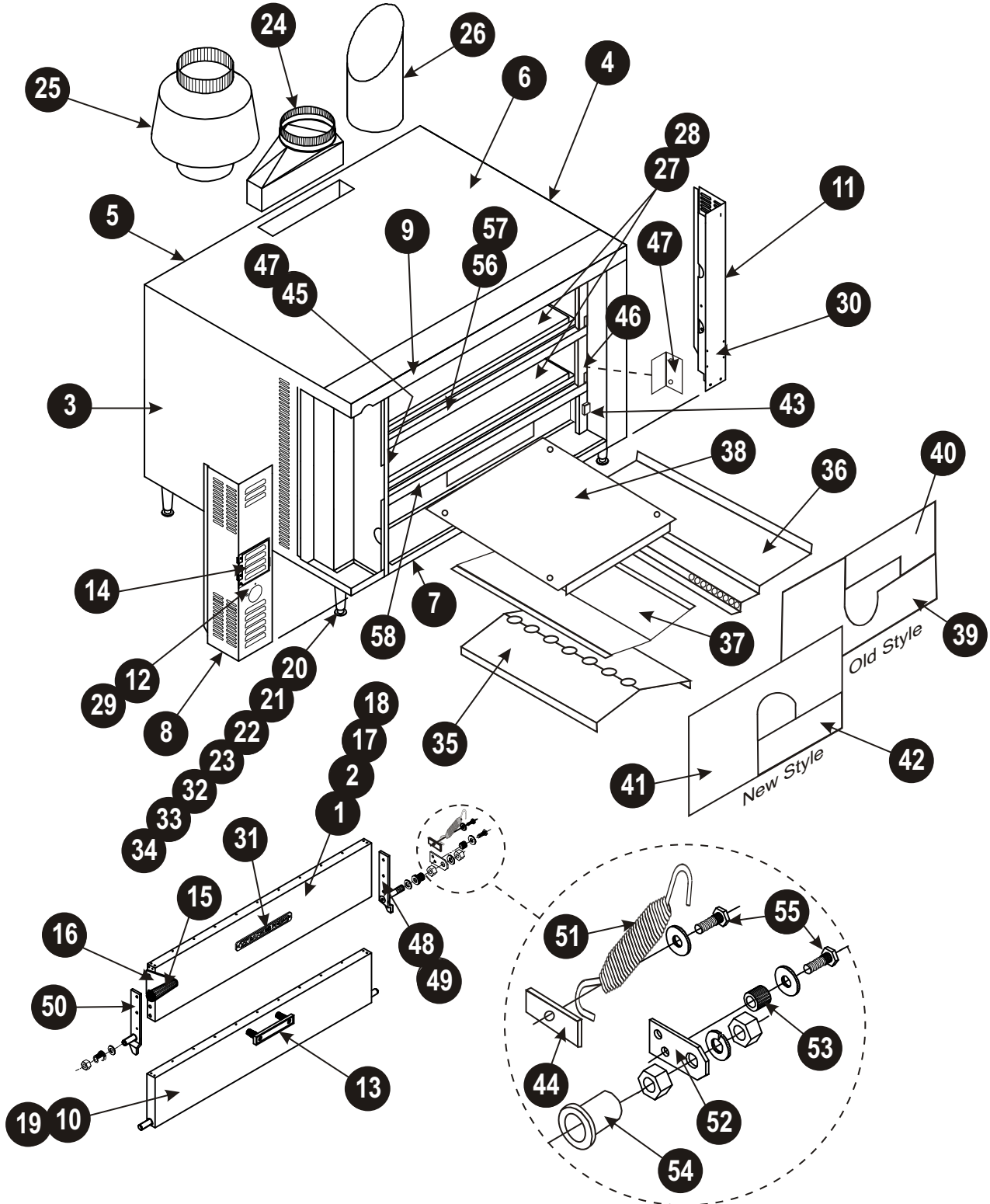

Note: When ordering, ALWAYS specify Part #, Model #, Serial # and type of gas.

9/05



30 Pine Street • New Rochelle • New York • 10801

914 / 576 - 0200
 914 / 576 - 0605 fax
 1 - 800 - 431 - 2745 US & Canada
 www.bakerspride.com web address

GP-61

Counter Top Gas Oven

Item	Part #	Description	Item	Part #	Description
Exterior / Decks					
1	A5228X	S/S Top Door Cover 14"	19	A5276X	Burner Door
2	A5229X	S/S Top Door Cover 7"	20	S1014A	4" Leg Adjustable
3	A5231X	Left Outer S/S Side	21	S1050Y	30" Leg Painted Gray
4	A5232X	Right Outer S/S Side	22	S1212Y	30" Leg S/S
5	A5233X	Back Outer S/S	23	S1241X	16" Leg S/S
6	A5234X	Top Outer S/S	24	R3087X	Flue Adapter 6"
7	A5225X	Bottom Trim	25	R3002X	Direct Vent Draft Flue 6"
8	A5226X	Control Panel	26	R3103X	Collection Hood Draft Flue w/o Tabs
9	A5235X	Top Trim	27	T1116Y	Ceramic Deck (each)
10	A5230X	Burner Door Cover S/S		T1080K	Steel Deck (each)
11	A5227X	Right Front Panel S/S	28	T1116X	Ceramic Deck (set of 2)
12	A4129X	Control Panel w/Lighting Instr. Plate	29	U1172X	Lighting Instruction Plate
13	S1149X	Burner Door Handle w/Screw	30	U1140X	Minimum Clearance Plate
14	A4129X	Control Door	31	U1044A	Bakers Pride Name Plate 8"
15	S1300X	Top Door Handle w/Screw	32	T8088X	Leg Shelf
16	A5253X	Door Handle Mount	33	S1022X	4" Casters w/No Locks
17	A5287X	Top Door 7"	34	S1023X	4" Casters w/Locks
18	A5286X	Top Door 14"			
Burner Compartment					
35	A5258X	Upper Breather Pan	40	A5252X	Burner Access Cover O/S
36	A5244X	Flue Deflector (Set: Left & Right)	41	A5301K	Combustion Chamber Front Center
37	A5237X	Slide Out Flame Diverter	42	A5302K	Burner Access Cover
38	A5259X	Insulation Pan (Set: Top & Bottom)	43	S3203X	Magnetic Latch Assembly
39	A5251X	Combustion Chamber Front Center O/S			
Door Rod & Accessories / Interior Trim					
44	A5288X	Spring Bracket	51	S3105X	Door Spring (used with 14" door)
45	A5291X	Left Door Stop	52	A5295X	Lever Arm
46	A5292X	Right Door Stop	53	S3007X	Roller
47	A5293X	Door Stop Shield (Fits on Left or Right)	54	S3008X	Bushing
48	A5297X	Right Door Arm Assembly	55	Q2301X	Shoulder Bolt
49	A5308X	Right Door Arm Assembly (Complete)	56	A5267X	Upper Deck Trim Assembly 7" Door
50	A5296X	Left Door Arm Assembly	57	A5305X	Upper Deck Trim Assembly 14" Door
51	S3004X	Door Spring (used with 7" door)	58	A5265X	Lower Deck Trim Assembly (All)
Quan	Part #	Description	Quan	Part #	Description
BGOR Conversion Kit (From Nat. to L.P)			BGOR Conversion Kit (From L.P. to Nat.)		
1	R3091X	Burner Orifice L/P (Drill #48)	1	R3146X	Burner Orifice N/G (Drill #30)
1	M1245X	Pilot Orifice L.P.	1	M1244X	Pilot Orifice N/G
1	M1221X	L/P BGOR or BMVR Valve Conversion Kit	1	M1297X	N/G BGOR Valve Conversion Kit
BMVR Conversion Kit (From Nat. to L.P.)			BMVR Conversion Kit (From L.P. to Nat.)		
1	R3091X	Burner Orifice L/P (Drill #48)	1	R3146X	Burner Orifice N/G (Drill #30)
1	M1245X	Pilot Orifice L.P.	1	M1244X	Pilot Orifice N/G
1	M1221X	L/P BGOR or BMVR Valve Conversion Kit	1	M1260X	N/G BMVR Valve Conversion Kit

9/05

Note: When ordering, ALWAYS specify Part #, Model #, Serial # and type of gas.

GP-61

Counter Top Gas Oven

30 Pine Street • New Rochelle • New York • 10801

914 / 576 - 0200

914 / 576 - 0605 fax

1 - 800 - 431 - 2745 US & Canada

www.bakerspride.com web address



Figure B	Burner	Item	Part #	Description
		59	L5036X	Burner w/Inspirator to Union w/o Orifice O/S
		60	L5095X	Burner w/Cap & Elbow O/S
		61	L5108X	Burner w/Inspirator to Union w/o Orifice
		62	L5096X	Burner w/Cap & Elbow
		63	K1237X	Pilot Bracket Adapter (Used on O/S Burner)
		64	M1220X	Pilot Burner N/G
		65	M1222X	Pilot Burner L/P
		66	M1244X	Pilot Orifice N/G
		67	M1245X	Pilot Orifice L.P.
		68	R3036X	S/S Pilot Tubing 45"
		69	L5032X	Inspirator #2
		70	R3075X	Spud Assembly #2 w/o Orifice
		71	R3146X	Burner Orifice N/G (Drill #30)
		72	R3091X	Burner Orifice L/P (Drill #48)
		73	R3080X	Blank Spud #2 (For #2 Inspirator)
	74	M1296X	Thermocouple T-46 (Used w/BGOR)	
	75	M1265X	Thermopile (Used w/BMVR)	

Figure C	Plumbing Control	Item	Part #	Description
		76 *	M1392X	Control Assy To Union N/G (BGOR)
		77 *	M1393X	Control Assy To Union L/P (BGOR)
		78	M1290X	Control Assy To Union N/G (BMVR) O/S
		79	M1291X	Control Assy To Union L/P (BMVR) O/S
		80	M1005X	Thermostat
		81	S1056X	Thermostat Knob "F"
		82	S1163X	Thermostat Knob "C"
		83	R3152X	7000 Valve, BGOR, N/G (After SN339, 8/98)
		84 *	R3154X	7000 Valve, BGOR, L/P (After SN339, 8/98)
		85	M1297X	N/G BGOR Valve Conversion Kit
		86	M1221X	L/P BGOR or BMVR Valve Conversion Kit
		87 *	R3156X	7000 Combo Valve N/G (Europe-BGOR)
		88	R3104X	7000 Valve, BMVR, N/G (Before SN440, 8/98)
		89	M1260X	N/G BMVR Valve Conversion Kit
		90	R3124X	7000 Valve, BMVR, L/P (Before SN440, 8/98)
	N/S	Q4021X	Capillary Clip (Thermostat Sensor)	
	N/S	A5173S	Stacking Bracket Kit	
		*	Discontinued 7/00.	Substitute BMVR parts listed above. ALWAYS INCLUDE #M1265X Thermopile.

Note: When ordering, ALWAYS specify Part #, Model #, Serial # and type of gas.

9/05



BAKERS PRIDE LIMITED WARRANTY

30 Pine Street New Rochelle, New York 10801
914 / 576 - 0200 ♦ US & Canada: 1 - 800 - 431 - 2745 ♦ fax 914 / 576 - 0605

WHAT IS COVERED This warranty covers defects in material and workmanship under normal use, and applies only to the original purchaser providing that:

- ♦ The equipment has not been accidentally or intentionally damaged, altered or misused;
- ♦ The equipment is properly installed, adjusted, operated and maintained in accordance with National and local codes, and in accordance with the installation instruction provided with the product;
- ♦ The serial number rating plate affixed to the equipment has not been defaced or removed.

WHO IS COVERED This warranty is extended to the original purchaser and applies only to equipment purchased for use in the U.S.A.

COVERAGE PERIOD Full size gas and electric deck ovens: Two (2) year limited parts and labor; Cyclone Convection Ovens: BCO Models: One (1) Year limited parts and labor; GDCO Models: Two (2) Year limited parts and labor; CO II Models: Two (2) Year limited parts and labor; (5) Year limited door warranty.

All Other Products: One (1) Year limited parts and labor.

Warranty period begins the date of dealer invoice to customer or ninety (90) days after shipment date from BAKERS PRIDE - whichever comes first.

WARRANTY COVERAGE This warranty covers on-site labor, parts and reasonable travel time and travel expenses of the authorized service representative up to (100) miles, round trip, and (2) hours travel time. The purchaser, however, shall be responsible for all expenses related to travel, including time, mileage and shipping expenses on smaller counter models that may be carried into a Factory Authorized Service Center, including the following models: PX-14, PX-16, PI8, and BK-18.

EXCEPTIONS All removable parts in BAKERS PRIDE Char-broilers, including but not limited to: Burners, Grates, Radiants, Stones and Valves, are covered for a period of SIX MONTHS.

All Ceramic Baking Decks are covered for a period of THREE MONTHS. The installation of these replacement decks is the responsibility of the purchaser.

The extended Cyclone door warranty years 3 through 5 is a parts only warranty and does not include labor, travel, mileage or any other charges.

EXCLUSIONS

- ♦ Negligence or acts of God,
- ♦ Thermostat calibrations after (30) days from equipment installation date,
- ♦ Air and Gas adjustments,
- ♦ Light bulbs,
- ♦ Glass doors and door adjustments,
- ♦ Fuses,
- ♦ Char-broiler work decks and cutting boards,
- ♦ Tightening of conveyor chains,
- ♦ Adjustments to burner flames and cleaning of pilot burners,
- ♦ Tightening of screws or fasteners,
- ♦ Failures caused by erratic voltages or gas supplies,
- ♦ Unauthorized repair by anyone other than a BAKERS PRIDE Factory Authorized Service Center,
- ♦ Damage in shipment,
- ♦ Alteration, misuse or improper installation,
- ♦ Thermostats and safety valves with broken capillary tubes,
- ♦ Accessories - spatulas, forks, steak turners, grate lifters, oven brushes, scrapers, peels, etc.,
- ♦ Freight - other than normal UPS charges,
- ♦ Ordinary wear and tear.

INSTALLATION Leveling and installation of decks, as well as proper installation and check out of all new equipment - per appropriate installation and use materials - is the responsibility of the dealer or installer, not the manufacturer.

REPLACEMENT PARTS BAKERS PRIDE genuine Factory OEM parts receive a (90) day materials warranty effective from the date of installation by a BAKERS PRIDE Factory Authorized Service Center.

This Warranty is in lieu of all other warranties, expressed or implied, and all other obligations or liabilities on the manufacturers part. BAKERS PRIDE shall in no event be liable for any special, indirect or consequential damages, or in any event for damages in excess of the purchase price of the unit. The repair or replacement of proven defective parts shall constitute a fulfillment of all obligations under the terms of this warranty.

Form #U4177A 1/07