



TRUE FOOD SERVICE EQUIPMENT, INC.

St. Charles Industrial Center • P.O. Box 970 • O'Fallon, Missouri 63366
 (636)240-2400 • FAX (636)272-2408 • (800)325-6152 • www.truemfg.com
 Parts Dept. (800)424-TRUE • Parts Dept. FAX# (636)272-9471

Project Name: _____

A/A #

Location: _____

Item #: _____ Qty: _____

SIS #

Model #: _____

Model:
TPP-93

Pizza Prep Table:
Solid Door Refrigerator



TPP-93

- ▶ True's pizza prep tables are designed with enduring quality that protects your long term investment.
- ▶ Oversized, environmentally friendly (R134A) forced-air refrigeration system holds 33°F to 41°F (.5°C to 5°C).
- ▶ Complies with and listed under ANSI/NSF-7-1997-6.3.
- ▶ All stainless steel front, top and cabinet ends. Matching aluminum finished back.
- ▶ Stainless steel, patented, foam insulated flat lids keeps pans' temperatures colder and locks in freshness. Also minimizes condensation.
- ▶ Extra-deep 19½" (496 mm) full length removable cutting board included. Sanitary, high density, NSF approved white polyethylene provides tough preparation surface.
- ▶ Foamed-in-place, high density polyurethane insulation (CFC free).
- ▶ Heavy duty PVC coated wire shelves.

ROUGH-IN DATA

Specifications subject to change without notice.
 Chart dimensions rounded up to the nearest 1/8" (millimeters rounded up to next whole number).

Model	Solid Doors	Capacity (Cu. Ft.) (liters)	# of Shelves	# of Pans (top)	Cabinet Dimensions (inches) (mm)			HP	Voltage	Amps	NEMA Config.	Cord Length (total ft.) (total m)	Crated Weight (lbs.) (kg)
					L**	D†	H*						
TPP-93	3	30.9 875	6	12	93¼	32¼	35¾	1/2	115/60/1	9.7	5-15P	7	570
					2369	820	909	1/2	230-240/50/1	4.2	▲	2.13	259

** Length does not include 1/4" (7 mm) each side for cutting board brackets and thumb screws.

▲ Plug type varies by country.

† Depth does not include 1" (26 mm) for rear bumpers and 3" (77 mm) for cutting board.

* Height does not include 6¼" (159 mm) for castors or 6" (153 mm) for optional legs.



APPROVALS:

Model:
TPP-93

Pizza Prep Table:
Solid Door Refrigerator



STANDARD FEATURES

DESIGN

- True's commitment to using the highest quality materials and oversized refrigeration systems provides the user with colder product temperatures, lower utility costs, superior food safety and the best value in today's food service marketplace.

REFRIGERATION SYSTEM

- Factory engineered, self-contained capillary tube system using environmentally friendly (CFC free) R134A refrigerant.
- Oversized, factory balanced refrigeration system with guided airflow to provide uniform temperature in food pan rail and cabinet interior.
- Forced-air design holds 33°F to 41°F (.5°C to 5°C) product temperature in food pans and cabinet interior. Complies with and listed under ANSI/NSF-7-1997-6.3.
- Condensing unit accessed from front behind removable panel on right hand side of cabinet, slides out for easy maintenance.

CABINET CONSTRUCTION

- Exterior - stainless steel front, top and cabinet ends. Matching aluminum finished back.
- Interior - attractive, NSF approved, white aluminum liner. 300 series stainless floor with coved corners.
- Insulation - entire cabinet structure and solid doors are foamed-in-place using high density, CFC free, polyurethane insulation.
- 5" (127 mm) diameter stem castors.
- 36" (915 mm) work surface height.

DOORS

- Stainless steel exterior with white aluminum liner to match cabinet interior.
- Doors swing within cabinet dimensions.
- Each door fitted with 12" (305 mm) long recessed handle that is foamed-in-place with a sheet metal interlock to insure permanent attachment.
- Magnetic door gaskets of one piece construction, removable without tools for ease of cleaning.

SHELVING

- Six (6) adjustable, heavy duty PVC coated wire shelves. Two (2) right and two (2) left door shelf dimensions are 23⁵/₈" L x 28" D (601 mm x 712 mm). Center door shelf dimensions are 25¹/₂" L x 28" D (648 mm x 712 mm). Four (4) chrome plated shelf clips included per shelf.
- Shelf support pilasters made of same material as cabinet interior; shelves are adjustable on 1/2" (13 mm) increments.

MODEL FEATURES

- Evaporator is epoxy coated to eliminate the potential of corrosion.
- Extra-deep 19¹/₂" (496 mm), full length removable cutting board included. Sanitary, high-density, NSF approved white polyethylene provides tough preparation surface.
- Stainless steel, patented, foam insulated flat lids keep pans' temperature colder and lock in freshness. Also minimizes condensation.

- Refrigerated pan rail comes standard with twelve (1/3 size) 12³/₄" L x 6¹/₄" W x 6" D (324 mm x 159 mm x 153 mm) NSF approved clear polycarbonate insert pans.
- NSF-7 compliant for open food product.

ELECTRICAL

- Unit completely pre-wired at factory and ready for final connection to a 115/60/1 phase - 15 amp dedicated outlet. Cord and plug set included.



115/60/1
NEMA-5-15R

OPTIONAL FEATURES/ACCESSORIES

Upcharge and lead times may apply.

- 230 - 240V / 50 Hz.
- 6" (153 mm) standard legs.
- 6" (153 mm) seismic/flanged legs.
- Garnish racks.
- Pizza prep service shelf.
- Single utility shelf.
- 19¹/₂" (496 mm) deep, 1/2" (13 mm) thick, white polyethylene cutting board. Requires "L" brackets.
- 19¹/₂" (496 mm) deep, 1/2" (13 mm) thick, composite cutting board. Requires "L" brackets.
- Half bun tray racks. Holds up to eleven 18" L x 26" D (158 mm x 661 mm) sheet pans (sold separately).
- Remote cabinets (condensing unit supplied by others), consult factory technical service department for BTU information.

PLAN VIEW

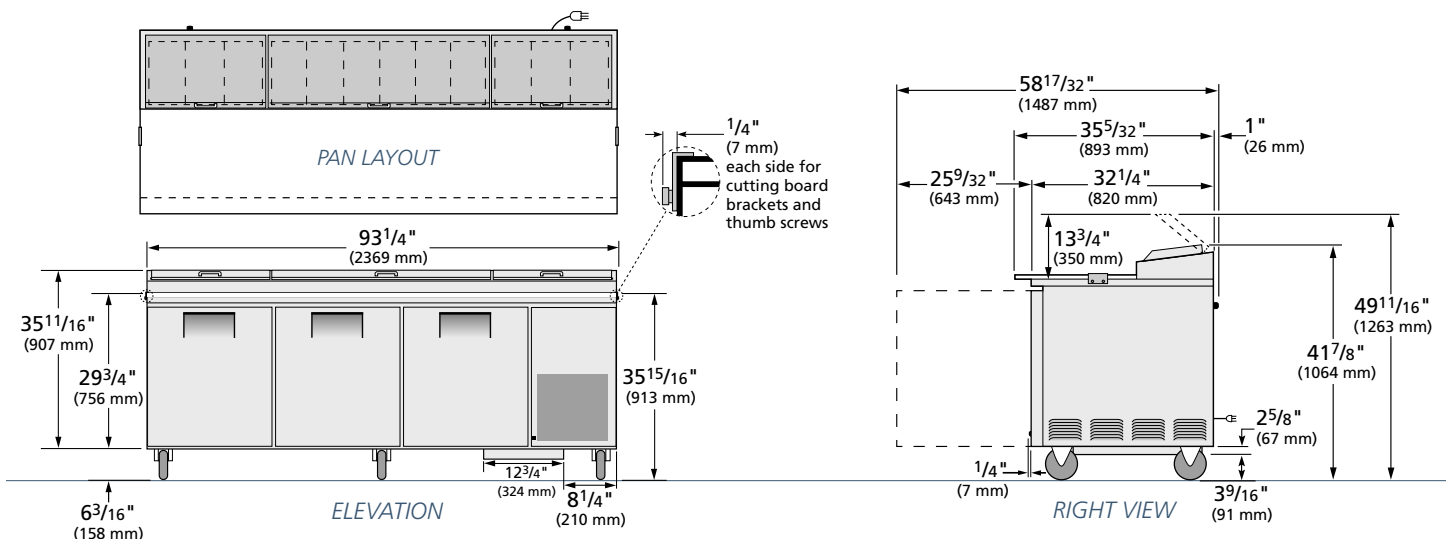

WARRANTY
One year warranty on all parts & labor and an additional 4 year warranty on compressor. (U.S.A. only)

METRIC DIMENSIONS ROUNDED UP TO THE NEAREST WHOLE MILLIMETER
SPECIFICATIONS SUBJECT TO CHANGE WITHOUT NOTICE



Model	Elevation	Right	Plan	3D
TPP-93	TFQY12E	TFQY15S	TFQY12P	TFQY123

TRUE FOOD SERVICE EQUIPMENT