

Worktop Freezers

Worktops
Super Deluxe Series

Exceptional Quality 2 Years Parts and Labor Warranty



TWF-28SD



TWF-48SD



TWF-60SD

FEATURES / BENEFITS

EFFICIENT REFRIGERATION SYSTEM

Turbo Air's solid door freezers are designed with oversized and balanced (CFC Free R-404A) refrigeration systems. These include efficient evaporators and condensers for faster freezing and greater efficiency.

STAINLESS STEEL CABINET CONSTRUCTION

The Turbo Air Super Deluxe model boasts a stainless steel interior and exterior (except the back). It guarantees the utmost in cleanliness and long product life. The Super Deluxe can add a touch of style to the most refined setting.

HIGH-DENSITY POLYURETHANE INSULATION

The entire cabinet structure and solid doors are formed-in-place using high density, CFC free polyurethane insulation.

STURDY, CLEAN STAINLESS SHELVING

Shelves are the most important part of cleanliness as they come in direct contact with food. After a while, PVC coated wire shelves may peel, rust and lead to unsanitary conditions. Only the Turbo Air Super Deluxe series uniquely provides stainless shelving.

ERGONOMICALLY DESIGNED DOOR

Customers' fatigue fades away with easy grip handles and doors that open effortlessly. These features along with self-closing doors make this the ultimate choice in customer convenience. ABS sheet door liners resist water condensation with thermal efficiency.

MAGNETIC DOOR GASKET

Magnetic door gaskets are of one piece construction, removable without tools for ease of cleaning and replacement.

HOT GAS CONDENSATE SYSTEM

Through Turbo Air's creative innovation, the condensate system surfaces have been specially treated to resist corrosion. This not only increases efficiency without the risk refrigerant leakage from corrosion, but also prevents the overflow of condensate water.

FREEZER HOLDS -5°F ~ -10°F FOR THE BEST IN FROZEN FOOD PRESERVATION

* Incandescent Interior Lighting

Model	Swing Door	CU./FT.	#of Shelves	HP	AMPS	Crated Weight	L D H
TWF-28SD	1	7	1	1/3	53	175	27 1/2 x 30 x 33 1/2
TWF-48SD	2	12	2	1/2	83	258	48 1/4 x 30 x 33 1/2
TWF-60SD	2	16	2	1/2	9	293	60 1/4 x 30 x 33 1/2

* Height does not include 6" for caster height.

TWF MODELS SPECIFICATIONS

MODEL	TWF-28SD	TWF-48SD	TWF-60SD
Exterior Dimension(LxDxH)	27 1/2x30x33 1/2	48 1/4x30x33 1/2	60 1/4x30x33 1/2
Cubic Feet	7	12	16
Compressor (HP)	1/3	1/2	1/2
# of Shelves	1 ea	2 ea	2 ea
Net Weight	157 lbs	235 lbs	254 lbs
Voltage (i) NEMA-5-15P	(i)115/60/1	(i)115/60/1	(i)115/60/1
Amp	5.3A	8.3A	9A
Lamp	25W	25W	25W
Cord Length (ft.)	9	9	9
Plug-In	NEMA 5-15P	NEMA 5-15P	NEMA 5-15P

*Design and specifications subject to change without notice.

- SELF-CONTAINED SYSTEM
- 2.5" CASTERS AVAILABLE FOR ALL MODELS (OPTIONAL)
- 5" SWIVEL CASTERS
- LEGS AVAILABLE FOR ALL MODELS (OPTIONAL)
- REMOTE CABINETS AND CONDENSING UNITS AVAILABLE FOR ALL MODELS.

- **WARRANTY :** 2 Years Labor and Parts Warranty
Additional 3 Years Warranty on Compressor

(unit : inch)

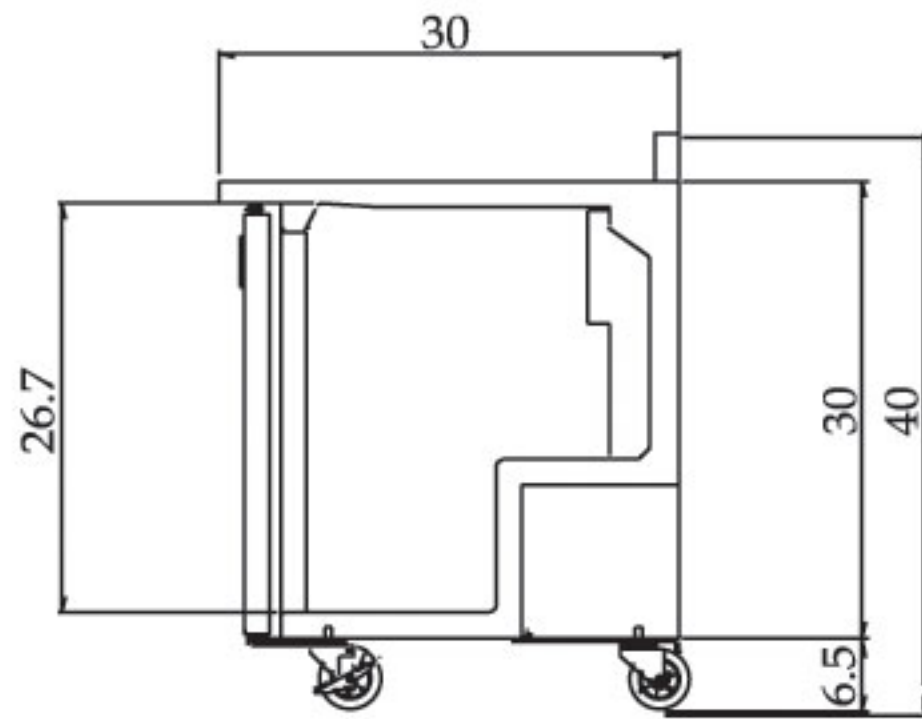

SIDE VIEW

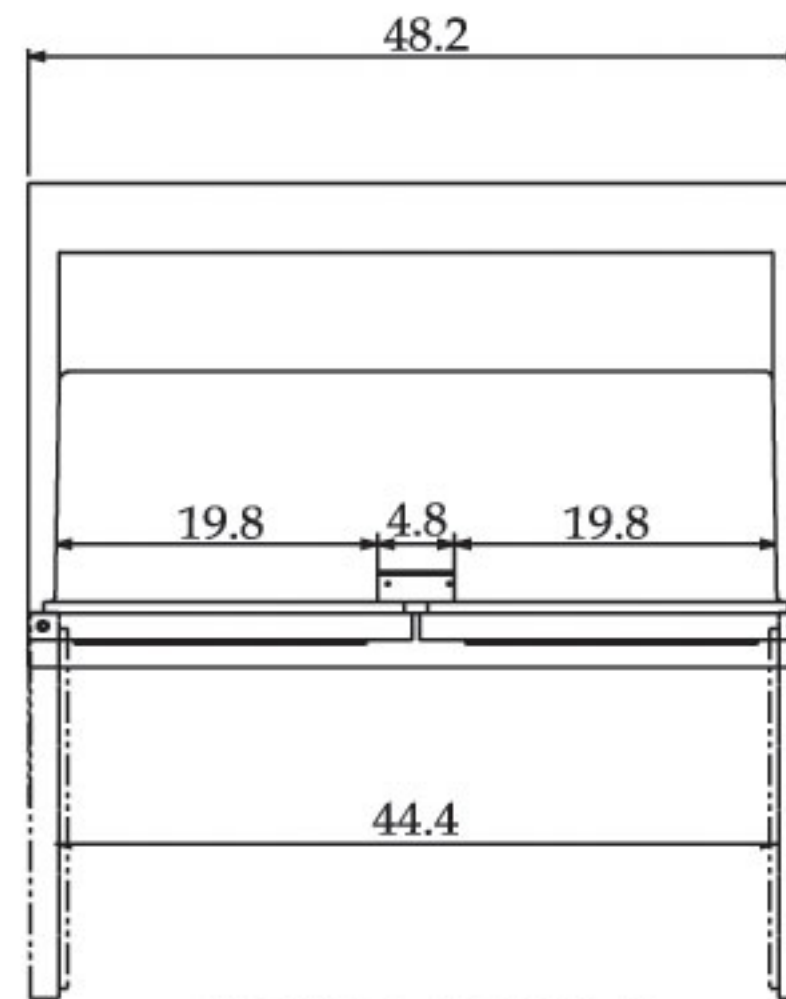

TWF-48SD PLAN VIEW

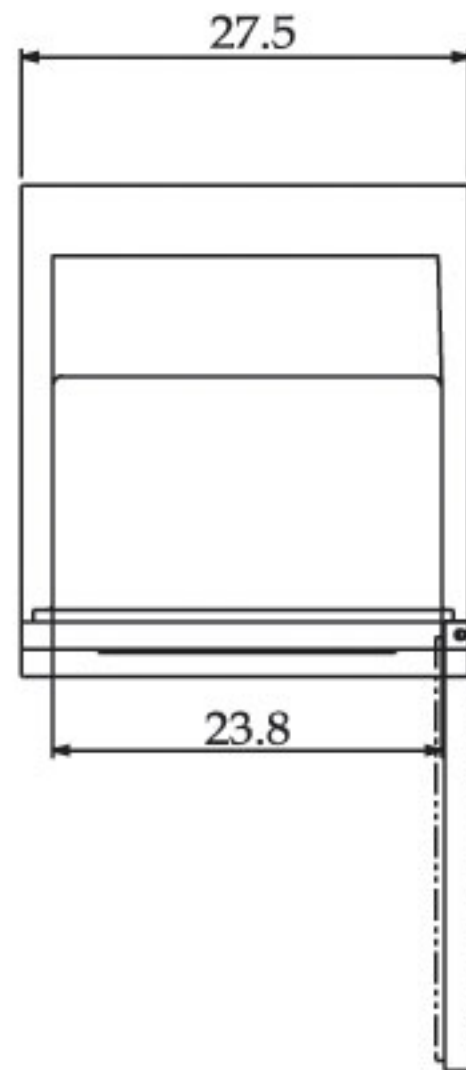

TWF-28SD PLAN VIEW

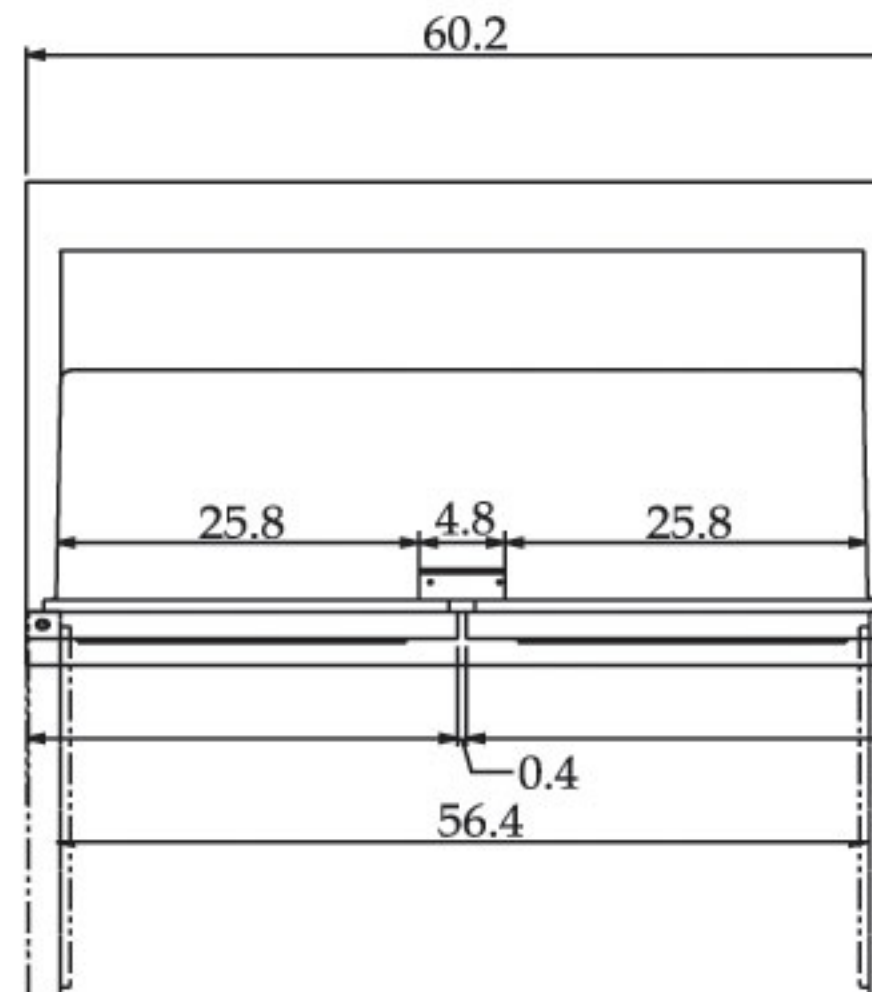

TWF-60SD PLAN VIEW